

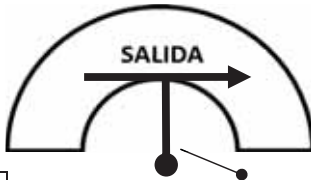



TC CH TC CH	0	SALIDA ZÓCALO DE TEHUACÁN.	DISTANCIA	0
	1	EL ZORRILLO 1	12.670 Km.	
			PROMEDIO-AVERAGE	TIEMPO TIME
			38 Km/h	00:25

DISTANCIA		DIRECCIÓN DIRECTION	TIERRA	INFORMACIÓN INFORMATION	DIST. REG.
TOTAL	PARCIAL				TO GO
0.000	0.000	 1		 CONTROL "CH" SALIDA ZÓCALO DE TEHUACÁN A LA DERECHA POR CALLE 1 ORIENTE.	12.670
0.050	0.050	 2		SEMAFORO DE FRENTE CATEDRAL LADO IZQUIERDO	12.620
0.120	0.070	 3		A LA IZQUIERDA POR CALLE 1 SUR.	14.840
0.250	0.130	 4		A LA DERECHA POR CALLE 3 ORIENTE	14.710
0.380	0.130	 5		SEMÁFORO A LA IZQUIERDA POR AV. REFORMA SUR.	14.580

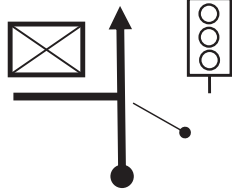

DISTANCIA A LA PRÓXIMA INSTRUCCIÓN	0.240
------------------------------------	-------

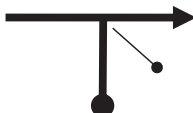
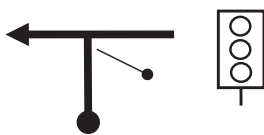
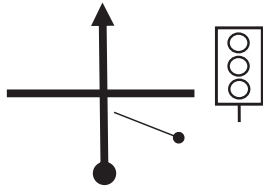
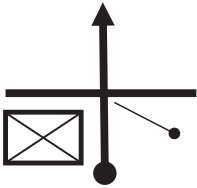
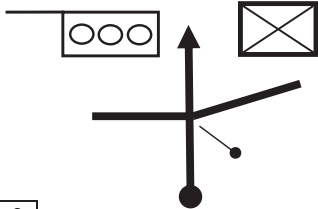
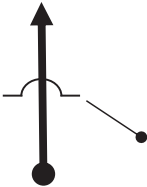
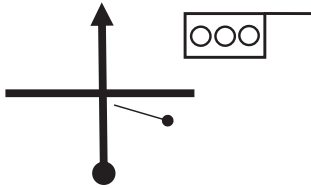
TC CH TC CH	0	SALIDA ZÓCALO DE TEHUACÁN.	DISTANCIA	<b>0</b>
	1	EL ZORRILLO 1	<b>12.670 Km.</b>	
			PROMEDIO-AVERAGE	TIEMPO TIME
			<b>38 Km/h</b>	<b>00:25</b>

DISTANCIA		DIRECCIÓN DIRECTION	TIERRA	INFORMACIÓN INFORMATION	DIST. REG. TO GO
TOTAL	PARCIAL				
0.620	0.240			<b>SEMÁFOROS (3) SEGUIR DE FRENTE</b>	14.340
		6			
1.260	0.640			<b>PEMEX LADO IZQUIERDO DE FRENTE</b>	13.700
		7			
1.370	0.110			<b>SEMÁFORO DE FRENTE (BODEGA AURRERÁ)</b>	13.590
		8			
2.000	0.630			<b>TOPES (2)</b>	12.960
		9			
2.340	0.340			<b>SEMÁFORO DE FRENTE</b>	12.620
		10			



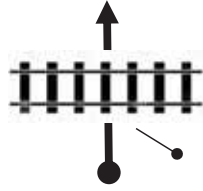
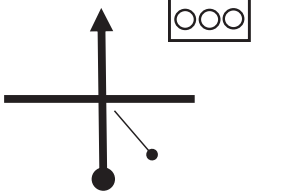

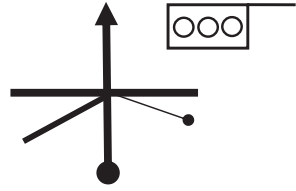
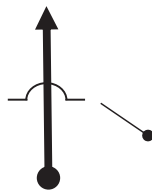

DISTANCIA A LA PRÓXIMA INSTRUCCIÓN	0.430
------------------------------------	-------

TC CH TC CH	0	SALIDA ZÓCALO DE TEHUACÁN.	DISTANCIA	0
	1	EL ZORRILLO 1	12.670 Km.	
			PROMEDIO-AVERAGE	TIEMPO TIME 00:25
			38 Km/h	

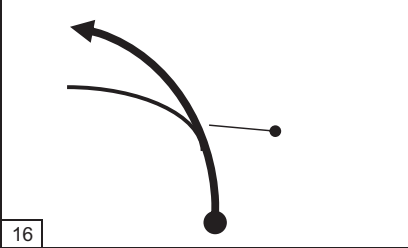
DISTANCIA		DIRECCIÓN DIRECTION	TIERRA	INFORMACIÓN INFORMATION	DIST. REG. TO GO
TOTAL	PARCIAL				
2.770	0.430	 11		CRUCE F.F.C.C.	12.190
2.910	0.140	 12		SEMÁFORO DE FRENTE	12.050
3.320	0.410	 13		TOPES (3)	11.640
4.310	0.990	 14		SEMÁFORO DE FRENTE	10.650
4.540	0.230	 15		TOPE	10.420

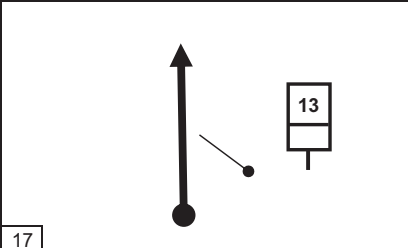
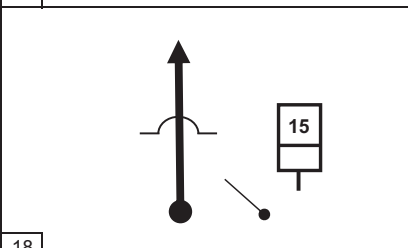
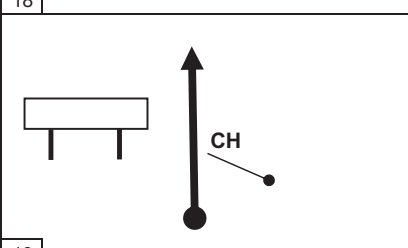
DISTANCIA A LA PRÓXIMA INSTRUCCIÓN	0.450
------------------------------------	-------

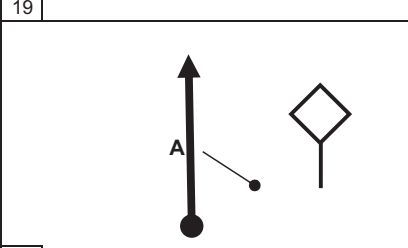
TC CH TC CH	0	SALIDA ZÓCALO DE TEHUACÁN.	DISTANCIA	0
	1	EL ZORRILLO 1	12.670 Km.	
			PROMEDIO-AVERAGE	TIEMPO TIME
			38 Km/h	00:25

DISTANCIA		DIRECCIÓN DIRECTION	TIERRA	INFORMACIÓN INFORMATION	DIST. REG. TO GO
TOTAL	PARCIAL				
4.990	0.450			  POR LA DERECHA A HUAJUAPAN	9.970
9.450	4.460			KM. 13	5.510
11.440	1.990			KM. 15 TOPES (4)	3.520
12.530	1.090			 CONTROL "CH"  LETRERO INVERTIDO	2.430
12.670	0.140			 CONTROL "A"  SEÑAL CURVAS	2.290

DISTANCIA A LA PRÓXIMA INSTRUCCIÓN

SS TC TC CH	1	EL ZORRILLO 1	DISTANCIA	1
	2	ACATEPEC	22.740 Km.	
1	EL ZORRILLO 1		9.790 Km.	PROMEDIO-AVERAGE
			68 Km/h	TIEMPO TIME 00:20

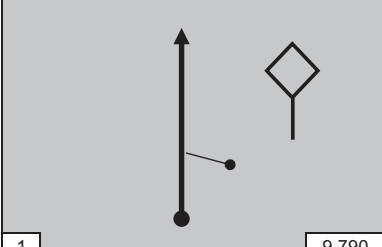
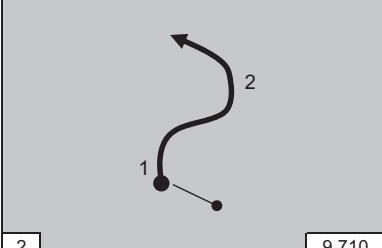
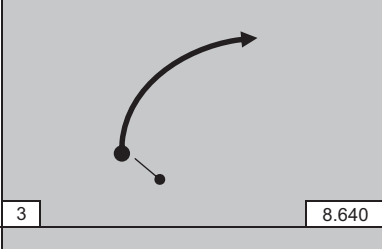
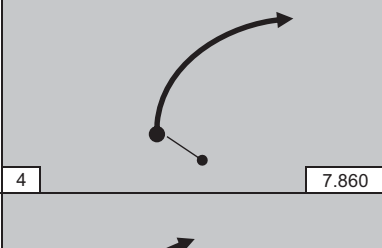
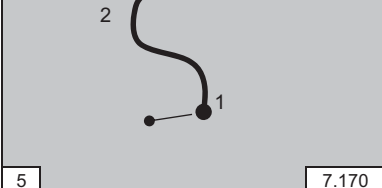
DISTANCIA		DIRECCIÓN DIRECTION	TIERRA	INFORMACIÓN INFORMATION	DIST. REG. TO GO
TOTAL	PARCIAL				
0.000	0.000	 1 9.790		<b>CONTROL "A"</b>  <b>SEÑAL CURVAS</b>  N18°23.444' W97°26.566'	22.740
0.080	0.080	 2 9.710		1 !!!  2 !!!	22.660
1.150	1.070	 3 8.640		!	21.590
1.930	0.780	 4 7.860		!!	20.810
2.620	0.690	 5 7.170		1 !!!  2 !!	20.120

DISTANCIA A LA PRÓXIMA INSTRUCCIÓN	2.590
------------------------------------	-------

SS TC TC CH	1	EL ZORRILLO 1	DISTANCIA		1
	2	ACATEPEC	22.740 Km.		
1	EL ZORRILLO 1		9.790 Km.	PROMEDIO-AVERAGE	TIEMPO TIME
				68 Km/h	00:20

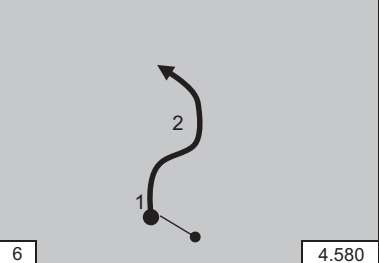
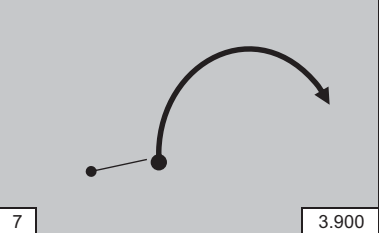
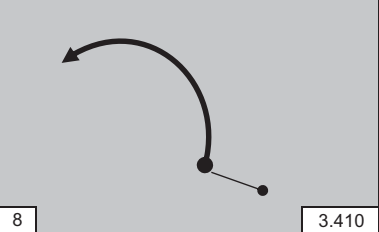
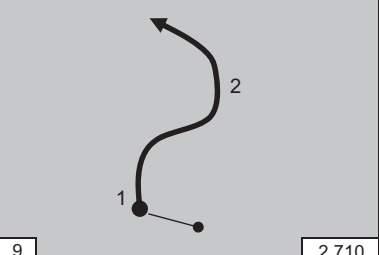
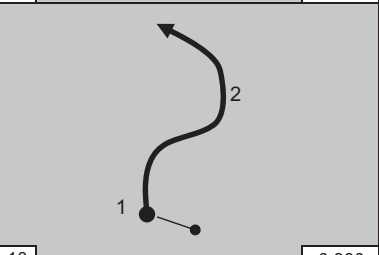
DISTANCIA		DIRECCIÓN DIRECTION	TIERRA	INFORMACIÓN INFORMATION	DIST. REG. TO GO
TOTAL	PARCIAL				
5.210	2.590			1 !! 2 !!	17.530
5.890	0.680			!!!	16.850
6.380	0.490			!!	16.360
7.080	0.700			1 !! 2 !!	15.660
8.890	1.810			1 !! 2 !!	13.850





DISTANCIA A LA PRÓXIMA INSTRUCCIÓN	0.900
------------------------------------	-------

SS TC TC CH	1	EL ZORRILLO 1	DISTANCIA		1
	2	ACATEPEC	22.740 Km.		
1	EL ZORRILLO 1		9.790 Km.	PROMEDIO-AVERAGE	TIEMPO TIME
				68 Km/h	00:20

DISTANCIA		DIRECCIÓN DIRECTION	TIERRA	INFORMACIÓN INFORMATION	DIST. REG. TO GO
TOTAL	PARCIAL				
9.790	0.900			CONTROL "B"  KM. 26  N18°20.044' W97°27.669'	12.950
10.100	0.310			CONTROL "C"  MARCA "FIN" EN PISO	12.640
10.400	0.300			PEMEX  ZAPOTILÁN  TOPES (5)	12.340
17.200	6.800			TELOXTOC	5.540
20.790	3.590			KM. 37	1.950

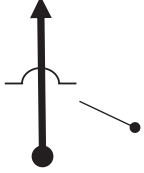
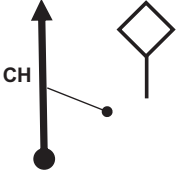
DISTANCIA A LA PRÓXIMA INSTRUCCIÓN	0.280
------------------------------------	-------

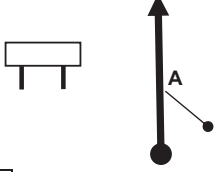
TC CH	1	EL ZORRILLO 1	DISTANCIA	1	
	2	ACATEPEC	22.740 Km.		
1	EL ZORRILLO 1		9.790 Km.	PROMEDIO-AVERAGE	
				68 Km/h	TIEMPO TIME 00:20

DISTANCIA		DIRECCIÓN DIRECTION	TIERRA	INFORMACIÓN INFORMATION	DIST. REG. TO GO
TOTAL	PARCIAL				
21.070	0.280	 16		TOPES (3)	1.670
22.630	1.560	 17		 CONTROL "CH" SEÑAL CURVA	0.110
22.740	0.110	 18		 CONTROL "A" LETRERO INVERTIDO	0.000

DISTANCIA A LA PRÓXIMA INSTRUCCIÓN 0.000



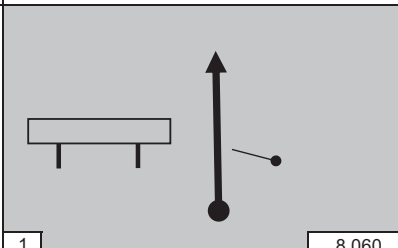
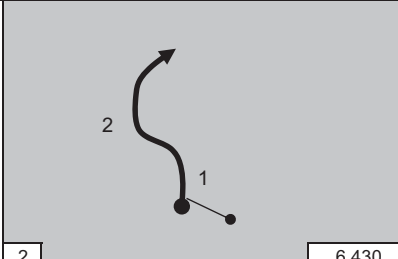
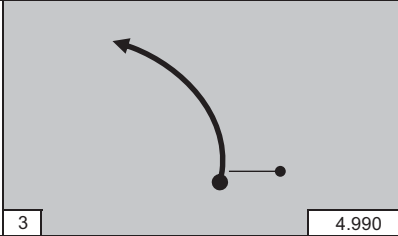
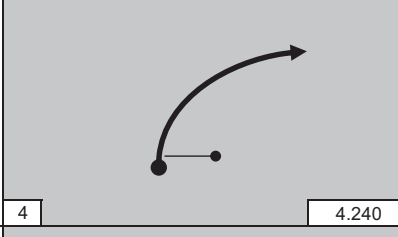
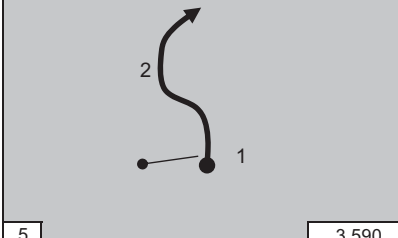

TC CH TC CH	2	ACATEPEC	DISTANCIA	2		
	3	CALTEPEC	13.310 Km.			
2	ACATEPEC		8.060 Km.	PROMEDIO-AVERAGE	TIEMPO TIME	00:13
				61.4 Km/h		

DISTANCIA		DIRECCIÓN DIRECTION	TIERRA	INFORMACIÓN INFORMATION	DIST. REG. TO GO
TOTAL	PARCIAL				
0.000	0.000			<b>CONTROL "A"</b>  LETRERO INVERTIDO  N18°16.020' W97°32.536'	13.310
1.630	1.630			1 !  2 !	11.680
3.070	1.440			<b>!! LARGA</b>	10.240
3.820	0.750			<b>!!</b>	9.490
4.470	0.650			1 !!  2 !!	8.840

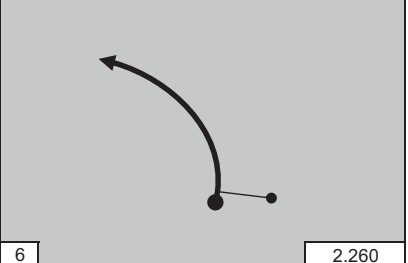
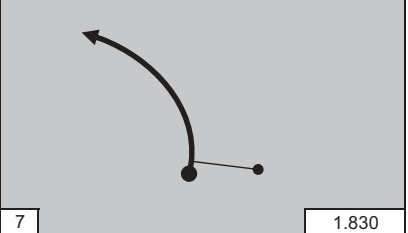
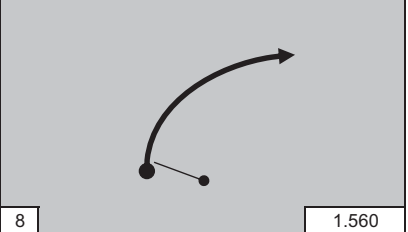
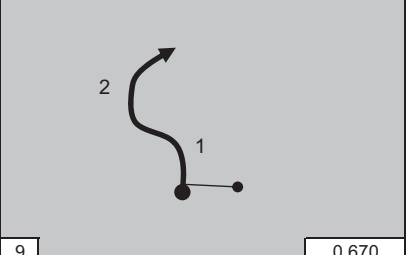
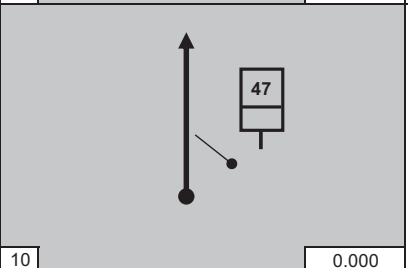

DISTANCIA A LA PRÓXIMA INSTRUCCIÓN	1.330
------------------------------------	-------

TC CH	2	ACATEPEC	DISTANCIA		2
	3	CALTEPEC	13.310 Km.		
TC CH	2	ACATEPEC	8.060 Km.	PROMEDIO-AVERAGE	TIEMPO TIME
				61.4 Km/h	

DISTANCIA		DIRECCIÓN DIRECTION	TIERRA	INFORMACIÓN INFORMATION	DIST. REG. TO GO
TOTAL	PARCIAL				
5.800	1.330	 6 2.260		!	7.510
6.230	0.430	 7 1.830		!	7.080
6.500	0.270	 8 1.560		!!	6.810
7.390	0.890	 9 0.670		1 !! 2 !!	5.920
8.060	0.670	 10 0.000		 CONTROL "B" KM. 47 N18°14.101' W97°34.677'	5.250



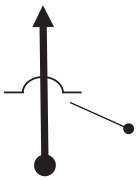
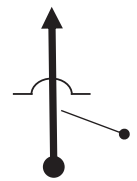
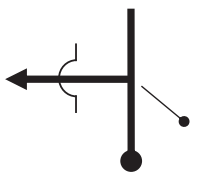

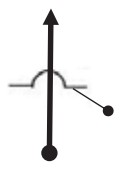
DISTANCIA A LA PRÓXIMA INSTRUCCIÓN	0.410
------------------------------------	-------

TC CH TC CH	2	ACATEPEC	DISTANCIA	2	
	3	CALTEPEC	13.310 Km.		
2	ACATEPEC		8.060 Km.	PROMEDIO-AVERAGE	
				61.4 Km/h	TIEMPO TIME
					00:13

DISTANCIA		DIRECCIÓN DIRECTION	TIERRA	INFORMACIÓN INFORMATION	DIST. REG. TO GO
TOTAL	PARCIAL				
8.470	0.410			<b>STOP</b> CONTROL "C" EN TOPE	4.840
		11			
8.770	0.300			TOPE	4.540
		12			
8.870	0.100			A LA IZQUIERDA EN ENTRONQUE A CALTEPEC TOPES (3)	4.440
		13			
11.040	2.170			KM. 2	2.270
		14			
11.240	0.200			TOPE	2.070
		15			

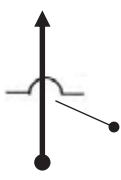
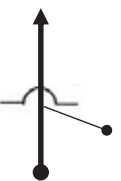

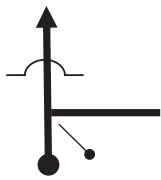
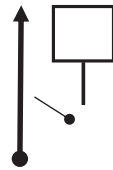
DISTANCIA A LA PRÓXIMA INSTRUCCIÓN	0.520
------------------------------------	-------

TC CH TC CH	2	ACATEPEC	DISTANCIA		2
	3	CALTEPEC	13.310 Km.		
2	ACATEPEC		8.060 Km.	PROMEDIO-AVERAGE	TIEMPO TIME
				61.4 Km/h	00:13

DISTANCIA		DIRECCIÓN DIRECTION	TIERRA	INFORMACIÓN INFORMATION	DIST. REG. TO GO
TOTAL	PARCIAL				
11.760	0.520			TOPE	1.550
		16			
12.750	0.990			TOPES (2)	0.560
		17			
13.050	0.300			KM. 4	0.260
		18			
13.110	0.060			DE FRENTE TOPE.	0.200
		19			
13.220	0.110			 CONTROL "CH" SEÑAL 40Km/h	0.090
		20			



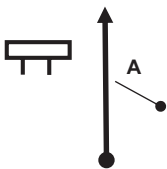



DISTANCIA A LA PRÓXIMA INSTRUCCIÓN	0.090
------------------------------------	-------

TC CH TC CH	2	ACATEPEC	DISTANCIA		2
	3	CALTEPEC	13.310 Km.		
2	ACATEPEC		8.060 Km.	PROMEDIO-AVERAGE	TIEMPO TIME
				61.4 Km/h	00:13

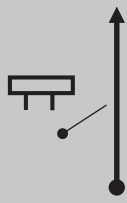
DISTANCIA		DIRECCIÓN DIRECTION	TIERRA	INFORMACIÓN INFORMATION	DIST. REG. TO GO
TOTAL	PARCIAL				
13.310	0.090			 <b>CONTROL "A"</b> <b>LETRERO INVERTIDO</b> <b>LADO IZQUIERDO.</b>	0.000
		21			
		22			



DISTANCIA A LA PRÓXIMA INSTRUCCIÓN	0.000
------------------------------------	-------

SS TC TC CH	3	CALTEPEC	DISTANCIA	3
	4	ATECOXCO	13.260 Km.	
3	CALTEPEC		11.820 Km.	PROMEDIO-AVERAGE
				53 Km/h
				TIEMPO TIME 00:15 + 01:00

DISTANCIA		DIRECCIÓN DIRECTION	TIERRA	INFORMACIÓN INFORMATION	DIST. REG. TO GO
TOTAL	PARCIAL				
0.000	0.000	 1 11.820		 <b>CONTROL "A"</b> LETRERO INVERTIDO  N18°12.231' W97°33.139'	13.260
0.880	0.880	 2 10.940		!!!	12.380
2.300	1.420	 3 9.520		!!	10.960
2.490	0.190	 4 9.330		1 !! 2 !	10.770
2.720	0.230	 5 9.100		1 ! 2 !!	10.540

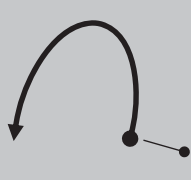
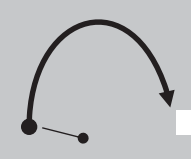

DISTANCIA A LA PRÓXIMA INSTRUCCIÓN	1.010
------------------------------------	-------

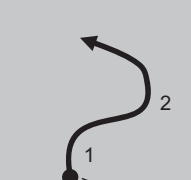
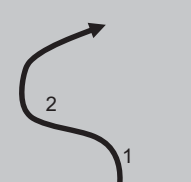
SS TC TC CH	3	CALTEPEC	DISTANCIA	3	
	4	ATECOXCO	13.260 Km.		
3	CALTEPEC		11.820 Km.	PROMEDIO-AVERAGE	
				53 Km/h	TIEMPO TIME 00:15 + 01:00

DISTANCIA		DIRECCIÓN DIRECTION	TIERRA	INFORMACIÓN INFORMATION	DIST. REG. TO GO
TOTAL	PARCIAL				
3.730	1.010			!!!	9.530
		6 8.090			
3.930	0.200			!!!	9.330
		7 7.890			
4.470	0.540			!!	8.790
		8 7.350			
4.580	0.110			1 !! 2 !!!	8.680
		9 7.240			
5.320	0.740			1 ! 2 !!	7.940
		10 6.500			

DISTANCIA A LA PRÓXIMA INSTRUCCIÓN	0.860
------------------------------------	-------

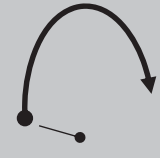
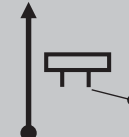
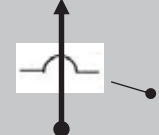
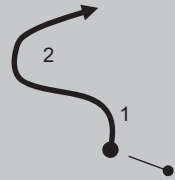





SS TC TC CH	3	CALTEPEC	DISTANCIA	<b>3</b>
	4	ATECOXCO	13.260 Km.	
3	CALTEPEC		11.820 Km.	PROMEDIO-AVERAGE
				53 Km/h
				TIEMPO TIME 00:15 + 01:00

DISTANCIA		DIRECCIÓN DIRECTION	TIERRA	INFORMACIÓN INFORMATION	DIST. REG. TO GO
TOTAL	PARCIAL				
6.180	0.860	 11 5.640		!!!	7.080
6.610	0.430	 12 5.210		LA COMPAÑÍA	6.650
6.970	0.360	 13 4.850		TOPES (2)	6.290
9.280	2.310	 14 2.540		1 ! 2 !!!	3.980
9.980	0.700	 15 1.840		!! LARGA	3.280

DISTANCIA A LA PRÓXIMA INSTRUCCIÓN	0.420
------------------------------------	-------

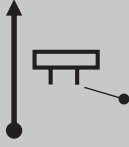

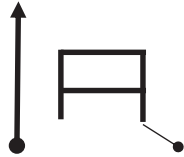
SS TC TC CH	3	CALTEPEC	DISTANCIA	3
	4	ATECOXCO	13.260 Km.	
3	CALTEPEC		11.820 Km.	PROMEDIO-AVERAGE
				53 Km/h
				TIEMPO TIME 00:15 + 01:00

DISTANCIA		DIRECCIÓN DIRECTION	TIERRA	INFORMACIÓN INFORMATION	DIST. REG. TO GO
TOTAL	PARCIAL				
10.400	0.420	 16 1.420		!!	2.860
11.110	0.710	 17 0.710			2.150
11.820	0.710	 18 0.000		 CONTROL "B" LETRERO POBLADO PRÓXIMO N18°11.274' W97°28.955'	1.440
12.110	0.290	 19		 CONTROL "C" LETRERO CALTEPEC INICIA ADOQUÍN	1.150
12.210	0.100	 20		TOPES (2)	1.050



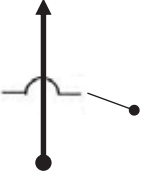
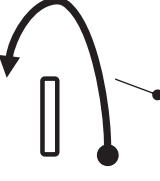
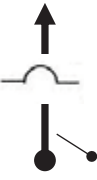
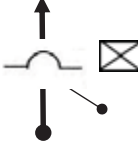

DISTANCIA A LA PRÓXIMA INSTRUCCIÓN	0.170
------------------------------------	-------

SS TC TC CH	3	CALTEPEC	DISTANCIA	3	
	4	ATECOXCO	13.260 Km.		
3	CALTEPEC		11.820 Km.	PROMEDIO-AVERAGE	
				53 Km/h	TIEMPO TIME 00:15 + 01:00

DISTANCIA		DIRECCIÓN DIRECTION	TIERRA	INFORMACIÓN INFORMATION	DIST. REG. TO GO
TOTAL	PARCIAL				
12.380	0.170			INICIA CAMELLÓN	0.880
12.490	0.110			TOPE	0.770
12.570	0.080			A LA IZQUIERDA EN "U", DONDE TERMINA CAMELLÓN	0.690
12.650	0.080			TOPE	0.610
12.860	0.210			ALTO, CASETA AZUL LADO DERECHO TOPES (2) L.D.	0.400

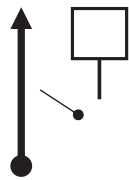

DISTANCIA A LA PRÓXIMA INSTRUCCIÓN	0.290
------------------------------------	-------

SS TC TC CH	3	CALTEPEC	DISTANCIA	3	
	4	ATECOXCO	13.260 Km.		
3	CALTEPEC		11.820 Km.	PROMEDIO-AVERAGE	
				53 Km/h	TIEMPO TIME 00:15 + 01:00

DISTANCIA		DIRECCIÓN DIRECTION	TIERRA	INFORMACIÓN INFORMATION	DIST. REG. TO GO
TOTAL	PARCIAL				
13.150	0.290			 CONTROL "CH" SEÑAL 40 Km/h	0.110
		26			
13.260	0.110			 CONTROL "A" POSTE SIN SEÑAL.	0.000
		27			

DISTANCIA A LA PRÓXIMA INSTRUCCIÓN

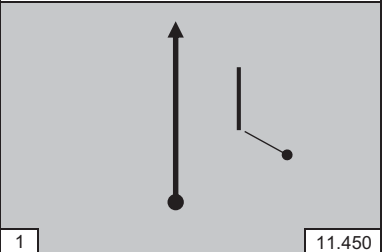
SS TC TC CH	4	ATECOXCO	DISTANCIA	4	
	5	CHAZUMBA	21.780 Km.		
4	ATECOXCO		11.450 Km	PROMEDIO-AVERAGE	TIEMPO TIME 00:22
				57 Km/h	

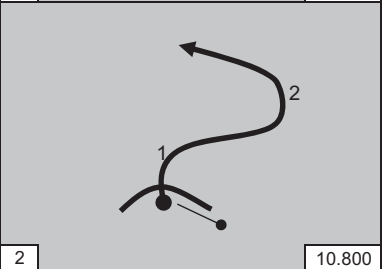
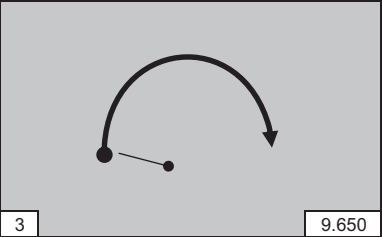
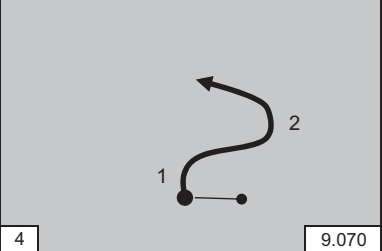
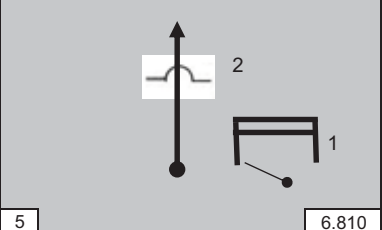
DISTANCIA		DIRECCIÓN DIRECTION	TIERRA	INFORMACIÓN INFORMATION	DIST. REG. TO GO
TOTAL	PARCIAL				
0.000	0.000			 <p><b>CONTROL "A"</b> POSTE SIN SEÑAL L.D.  N18°11.243' W97°28.929'</p>	21.780
0.650	0.650			<p><b>LOMO</b></p> <p>1 !</p> <p>2 !!!</p>	21.130
1.800	1.150			<p>!!</p>	19.980
2.380	0.580			<p>1 !</p> <p>2 !!!</p>	19.400
4.640	2.260			<p>1 LA COMPAÑÍA</p> <p>2 TOPES (2)</p>	17.140

DISTANCIA A LA PRÓXIMA INSTRUCCIÓN	0.700
------------------------------------	-------

SS TC TC CH	4	ATECOXCO	DISTANCIA	4	
	5	CHAZUMBA	21.780 Km.		
4	ATECOXCO		11.450 Km	PROMEDIO-AVERAGE	
				57 Km/h	TIEMPO TIME 00:22

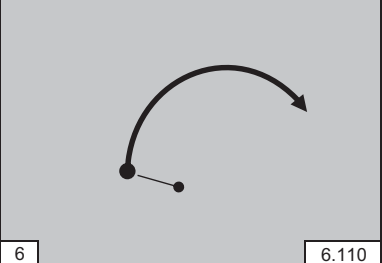
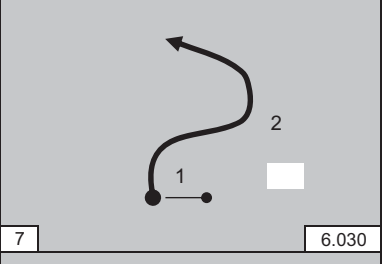
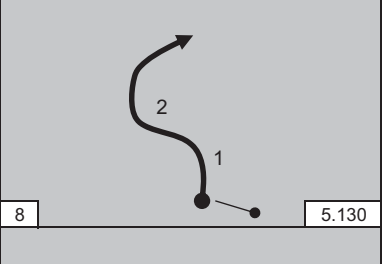
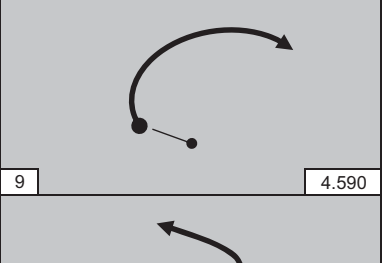
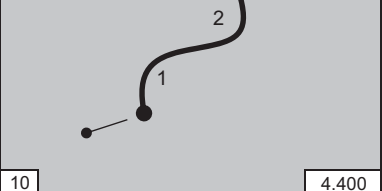
DISTANCIA		DIRECCIÓN DIRECTION	TIERRA	INFORMACIÓN INFORMATION	DIST. REG. TO GO
TOTAL	PARCIAL				
5.340	0.700			!	16.440
5.420	0.080			1 ! 2 !!!	16.360
6.320	0.900			1 !! 2 !	15.460
6.860	0.540			!	14.920
7.050	0.190			1 !! 2 !	14.730





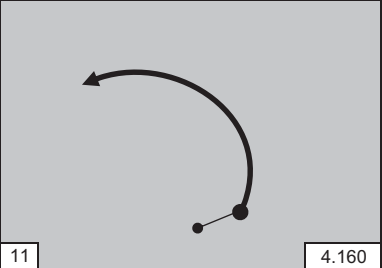
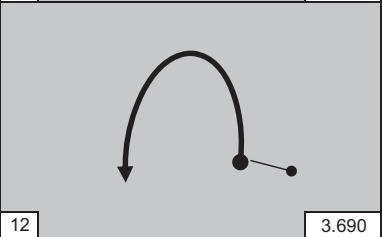
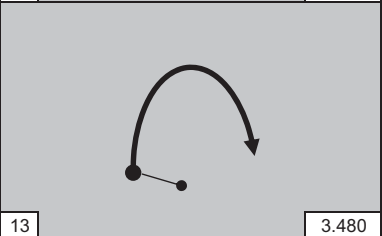
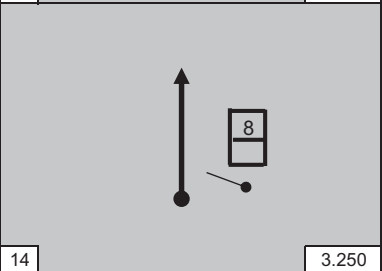
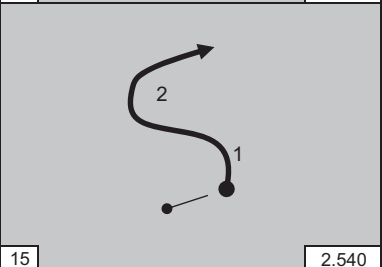

DISTANCIA A LA PRÓXIMA INSTRUCCIÓN 0.240

SS TC TC CH	4	ATECOXCO	DISTANCIA	4	
	5	CHAZUMBA	21.780 Km.		
4	ATECOXCO		11.450 Km	PROMEDIO-AVERAGE	
				57 Km/h	TIEMPO TIME 00:22

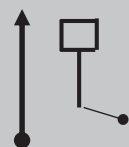
DISTANCIA		DIRECCIÓN DIRECTION	TIERRA	INFORMACIÓN INFORMATION	DIST. REG. TO GO
TOTAL	PARCIAL				
7.290	0.240			!	14.490
7.760	0.470			!!!	14.020
7.970	0.210			!!!	13.810
8.200	0.230			KM. 8	13.580
8.910	0.710			1 !! 2 !	12.870

DISTANCIA A LA PRÓXIMA INSTRUCCIÓN	1.930
------------------------------------	-------

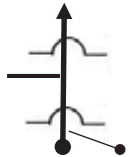
SS TC TC CH	4	ATECOXCO	DISTANCIA	4	
	5	CHAZUMBA	21.780 Km.		
4	ATECOXCO		11.450 Km	PROMEDIO-AVERAGE	TIEMPO TIME 00:22
				57 Km/h	

DISTANCIA		DIRECCIÓN DIRECTION	TIERRA	INFORMACIÓN INFORMATION	DIST. REG. TO GO
TOTAL	PARCIAL				
10.840	1.930	 16 0.610		!!	10.940
11.450	0.610	 17 0.000		 CONTROL "B" SEÑAL 40 KM/H N18°12.055' W97°32.949'	10.330
11.820	0.370	 18		 CONTROL "C" LETRERO POBLADO PRÓXIMO.	9.960
12.010	0.190	 19		TOPE ENTRONQUE TOPE	9.770
12.130	0.120	 20		TOPES (2)	9.650

DISTANCIA A LA PRÓXIMA INSTRUCCIÓN	1.290
------------------------------------	-------



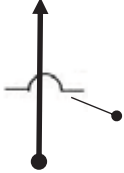
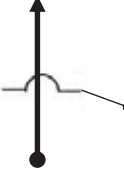
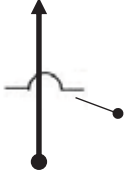
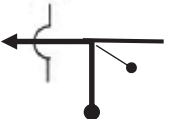
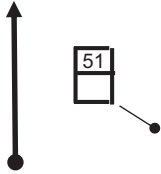

SS TC TC CH	4	ATECOXCO	DISTANCIA	4	
	5	CHAZUMBA	21.780 Km.		
4	ATECOXCO		11.450 Km	PROMEDIO-AVERAGE	TIEMPO TIME 00:22
				57 Km/h	

DISTANCIA		DIRECCIÓN DIRECTION	TIERRA	INFORMACIÓN INFORMATION	DIST. REG. TO GO
TOTAL	PARCIAL				
13.420	1.290			TOPE	8.360
		21			
13.940	0.520			TOPE	7.840
		22			
16.060	2.120			TOPES (3)	5.720
		23			
16.290	0.230			A LA IZQUIERDA POR CARRETERA FEDERAL Y TOPE	5.490
		24			
19.390	3.100			KM. 51	2.390
		25			

DISTANCIA A LA PRÓXIMA INSTRUCCIÓN	2.190
------------------------------------	-------



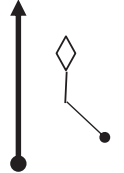

SS TC TC CH	4	ATECOXCO	DISTANCIA	4	
	5	CHAZUMBA	21.780 Km.		
4	ATECOXCO		11.450 Km	PROMEDIO-AVERAGE	
				57 Km/h	TIEMPO TIME 00:22

DISTANCIA		DIRECCIÓN DIRECTION	TIERRA	INFORMACIÓN INFORMATION	DIST. REG. TO GO
TOTAL	PARCIAL				
21.580	2.190			 <b>CONTROL "CH"</b> INICIO DE RIEL LADO DERECHO	0.200
		26			
21.780	0.200			 <b>CONTROL "A"</b> SEÑAL CURVA	0.000
		27			

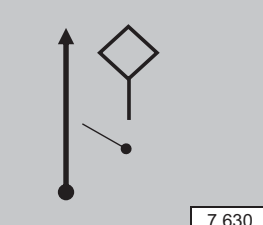

DISTANCIA A LA PRÓXIMA INSTRUCCIÓN

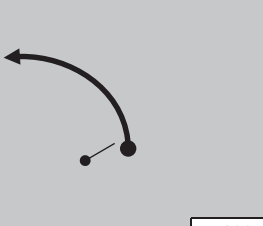
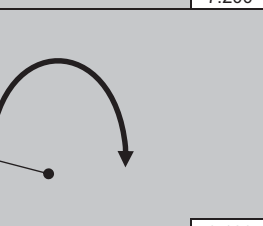
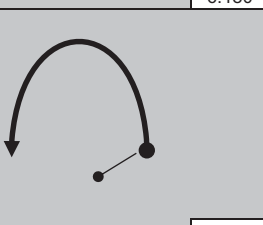
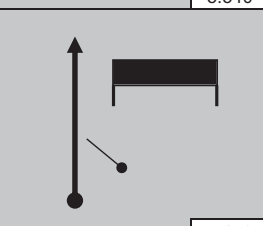
SS TC TC CH	5	CHAZUMBA	DISTANCIA	5	
	5A	SERVICIO 1 EN GASOLINERA CHAZUMBA	8.930 Km.		
5	CHAZUMBA		7.630 Km.	PROMEDIO-AVERAGE	TIEMPO TIME 00:09
				59.5 Km/h	

DISTANCIA		DIRECCIÓN DIRECTION	TIERRA	INFORMACIÓN INFORMATION	DIST. REG. TO GO
TOTAL	PARCIAL				
0.000	0.000			 <b>CONTROL "A"</b> <b>SEÑAL CURVA</b> N18°12' 50.84" W97°37' 37.80"	8.930
0.430	0.430				8.500
1.450	1.020			!!!	7.480
2.090	0.640			!!!	6.840
2.460	0.370			<b>PRIMER LETRERO</b> <b>BIENVENIDOS A OAXACA</b>	6.470



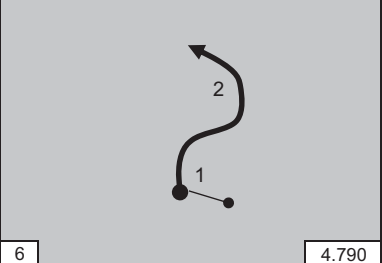
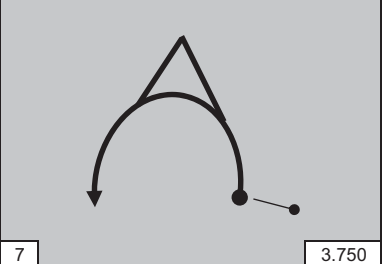
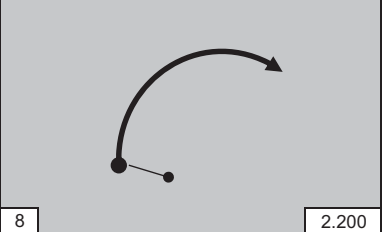
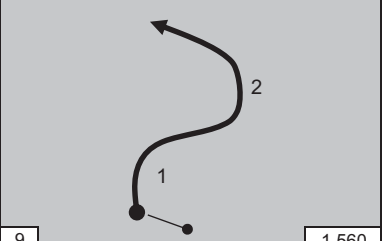
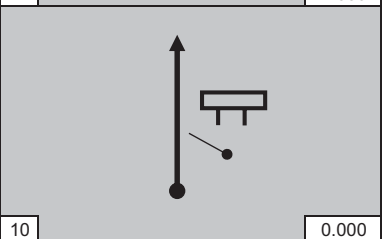

DISTANCIA A LA PRÓXIMA INSTRUCCIÓN	0.380
------------------------------------	-------

SS TC TC CH	5	CHAZUMBA	DISTANCIA	5	
	5A	SERVICIO EN GASOLINERA CHAZUMBA	8.930 Km.		
5	CHAZUMBA		7.630 Km.	PROMEDIO-AVERAGE	
				59.5 Km/h	TIEMPO TIME 00:09

DISTANCIA		DIRECCIÓN DIRECTION	TIERRA	INFORMACIÓN INFORMATION	DIST. REG. TO GO
TOTAL	PARCIAL				
2.840	0.380			1 ! 2 !	6.090
3.880	1.040			!!	5.050
5.430	1.550			!!	3.500
6.070	0.640			1 !! 2 !!	2.860
7.630	1.560			 CONTROL "B" LETRERO NO DEJE PIEDRAS... N18°12' 03.87" W97°40' 20.09"	1.300

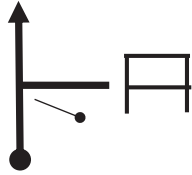

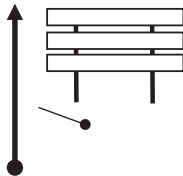
DISTANCIA A LA PRÓXIMA INSTRUCCIÓN	0.580
------------------------------------	-------

SS TC TC CH	5	CHAZUMBA	DISTANCIA	5	
	5A	SERVICIO EN GASOLINERA CHAZUMBA	8.930 Km.		
5	CHAZUMBA		7.630 Km.	PROMEDIO-AVERAGE	TIEMPO TIME
				59.5 Km/h	

DISTANCIA		DIRECCIÓN	TIERRA	INFORMACIÓN INFORMATION	DIST. REG. TO GO
TOTAL	PARCIAL				
8.210	0.580	 11		 CONTROL "C"  CONSTRUYE...	0.720
8.820	0.610	 12		 CONTROL "CH"  ENTRADA AL SERVICIO LETRERO TRIPLE.	0.110
8.930	0.110	 13		PEMEX LADO DERECHO AREA DE SERVICIO.	0.000



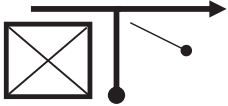
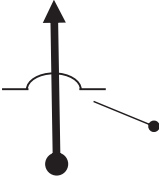
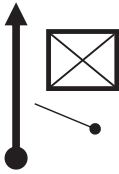

DISTANCIA A LA PRÓXIMA INSTRUCCIÓN

TC CH TC CH	5A	SERVICIO EN GASOLINERA CHAZUMBA	DISTANCIA	5A
	5B	ENTRADA A RECLASIFICACION	0.320 Km.	
			PROMEDIO-AVERAGE	01:00

DISTANCIA		DIRECCIÓN DIRECTION	TIERRA	INFORMACIÓN INFORMATION	DIST. REG. TO GO
TOTAL	PARCIAL				
0.000	0.000	 1		SALIDA DE GASOLINERA	0.320
0.030	0.030	 2		TOPES (2)	0.290
0.320	0.290	 3		 CONTROL "CH" ENTRADA A RECLASIFICACIÓN GASOLINERA ABANDONADA	0.000

DISTANCIA A LA PRÓXIMA INSTRUCCIÓN

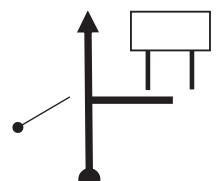
TC	5B	ENTRADA A RECLASIFICACION	DISTANCIA	<b>5B</b>
CH			0.110 Km.	
TC	5C	SALIDA DE RECLASIFICACION	PROMEDIO-AVERAGE	00:15
CH				

DISTANCIA		DIRECCIÓN DIRECTION	TIERRA	INFORMACIÓN INFORMATION	DIST. REG. TO GO
TOTAL	PARCIAL				
0.000	0.000			 <b>CONTROL "CH"</b>  ENTRADA A RECLASIFICACIÓN GASOLINERA ABANDONADA	0.110
		1			
0.110	0.110			 <b>CONTROL "CH"</b>  SALIDA DE RECLASIFICACIÓN LETRERO "SASCH"	0.000
		2			



DISTANCIA A LA PRÓXIMA INSTRUCCIÓN 0.120

51° RALLY MEDIA NOCHE

jmgf-2017

[www.cnrm.com.mx](http://www.cnrm.com.mx)

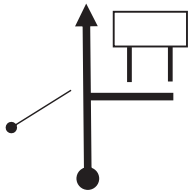
TC CH TC CH	5C	SALIDA DE RECLASIFICACION	DISTANCIA	5C
	6	JOLUXTLA 1	3.780 Km.	
			PROMEDIO-AVERAGE	TIEMPO TIME 00:05
			45.4 Km/h.	

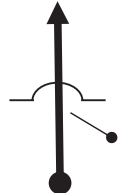
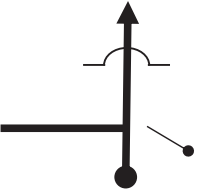
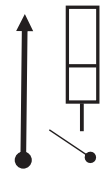
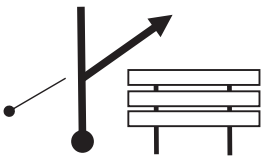
DISTANCIA		DIRECCIÓN DIRECTION	TIERRA	INFORMACIÓN INFORMATION	DIST. REG. TO GO
TOTAL	PARCIAL				
0.000	0.000			 CONTROL "CH"  SALIDA DE RECLASIFICACION LETRERO "SASCH"	
		1			
0.150	0.150			TOPE	
		2			
0.530	0.380			DE FRENTE, TOPE	
		3			
1.230	0.700			KM. 66	
		4			
1.390	0.160			A LA DERECHA LETRERO TRIPLE.	
		5			





51° RALLY MEDIA NOCHE

jmgf-17

[www.cnrm.com.mx](http://www.cnrm.com.mx)

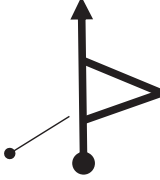
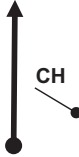





DISTANCIA A LA PRÓXIMA INSTRUCCIÓN	2.230
------------------------------------	-------

TC CH TC CH	5C	SALIDA DE RECLASIFICACION	DISTANCIA	5C
	6	JOLUXTLA 1	3.780 Km.	
			PROMEDIO-AVERAGE	TIEMPO TIME 00:05
			45.4 Km/h.	

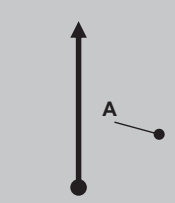
DISTANCIA		DIRECCIÓN DIRECCION	TIERRA	INFORMACIÓN INFORMATION	DIST. REG. TO GO
TOTAL	PARCIAL				
3.620	2.230			ENTRONQUE DE FRENTE.	
3.730	0.110			 CONTROL "CH"  MARCA EN PISO.	
3.780	0.050			 CONTROL "A"  MARCA EN PISO Y CUNETETA.	



SS TC CH	6	JOLUXTLA 1	DISTANCIA	6	
	7	LUNATITLÁN 1	9.630 Km.		
6	JOLUXTLA 1		8.020 Km.	PROMEDIO-AVERAGE	
				58 Km/h	TIEMPO TIME 00:10

DISTANCIA		DIRECCIÓN DIRECTION	TIERRA	INFORMACIÓN INFORMATION	DIST. REG. TO GO
TOTAL	PARCIAL				
0.000	0.000	 1 8.020		 CONTROL "A" MARCA EN PISO N18°10.248' W97°41.928'	9.630
1.330	1.330	 2 6.690		!!!	8.300
1.850	0.520	 3 6.170		PUENTE	7.780
2.290	0.440	 4 5.730		POR CARRIL IZQUIERDO ENTRONQUE HUAXTEPEC !!	7.340
2.560	0.270	 5 5.460		Km. 5 !!!	7.070

DISTANCIA A LA PRÓXIMA INSTRUCCIÓN	0.150
------------------------------------	-------

SS TC TC CH	6	JOLUXTLA 1	DISTANCIA	6
	7	LUNATITLÁN 1	9.630 Km.	
6	JOLUXTLA 1	8.020 Km.	PROMEDIO-AVERAGE	TIEMPO TIME
			58 Km/h	00:10

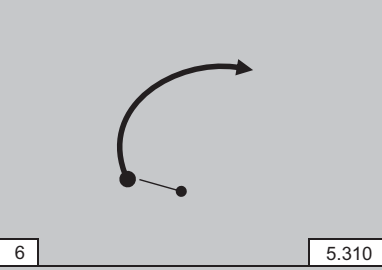
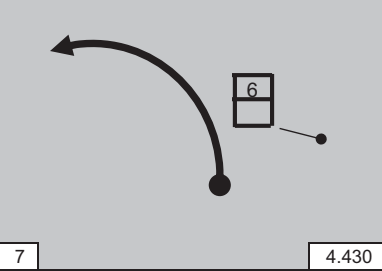
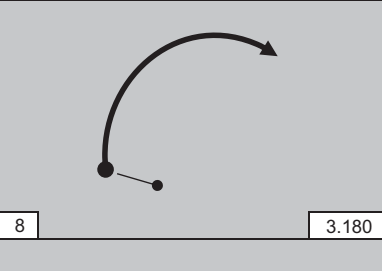
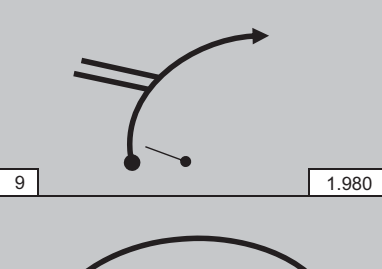
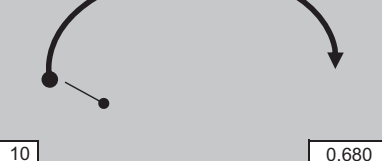
DISTANCIA		DIRECCIÓN DIRECTION	TIERRA	INFORMACIÓN INFORMATION	DIST. REG. TO GO
TOTAL	PARCIAL				
2.710	0.150			!!	6.920
3.590	0.880				6.040
4.840	1.250			!!	4.790
6.040	1.200			ENTRONQUE ACAQUIZAPAN !	3.590
7.340	1.300			DERECHA LARGA. !	2.290

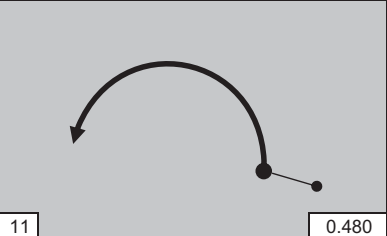
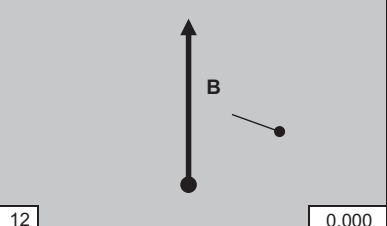
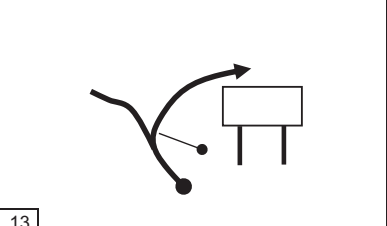
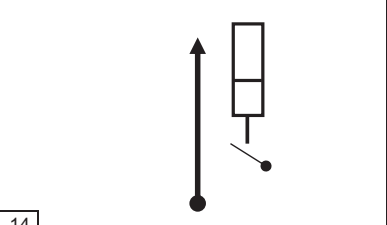
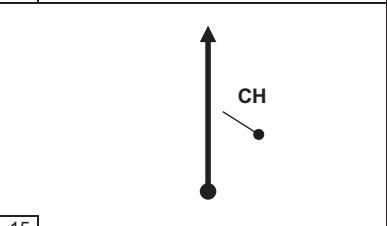

DISTANCIA A LA PRÓXIMA INSTRUCCIÓN	0.200
------------------------------------	-------

SS TC TC CH	6	JOLUXTLA 1	DISTANCIA	6
	7	LUNATITLÁN 1	9.630 Km.	
6	JOLUXTLA 1	8.020 Km.	PROMEDIO-AVERAGE	TIEMPO TIME
			58 Km/h	00:10

DISTANCIA		DIRECCIÓN	TIERRA	INFORMACIÓN INFORMATION	DIST. REG. TO GO
TOTAL	PARCIAL				
7.540	0.200			!! Y KM. 10	2.090
8.020	0.480			<b>CONTROL "B"</b> MARCA EN PISO Y ROCA L.D.  N18°09.247' W97°44.447'	1.610
8.350	0.330			<b>STOP CONTROL "C"</b>  EN ENTRONQUE Y LETRERO MOVER A MEXICO	1.280
8.950	0.600			KM. 10	0.680
9.570	0.620			<b>CONTROL "CH"</b>  MARCA EN PISO Y CASA L.I.	0.060

DISTANCIA A LA PRÓXIMA INSTRUCCIÓN	0.060
------------------------------------	-------

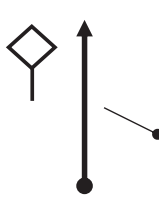
SS TC TC CH	6	JOLUXTLA 1	DISTANCIA		6
	7	LUNATITLÁN 1	9.630 Km.		
6	JOLUXTLA 1		8.020 Km.	PROMEDIO-AVERAGE	
				58 Km/h	TIEMPO TIME 00:10

DISTANCIA		DIRECCIÓN DIRECTION	TIERRA	INFORMACIÓN INFORMATION	DIST. REG. TO GO
TOTAL	PARCIAL				
9.630	0.060			 CONTROL "A" SEÑAL INVERTIDA LADO IZQUIERDO	0,000
		16			

DISTANCIA A LA PRÓXIMA INSTRUCCIÓN



51° RALLY MEDIA NOCHE

jmgf-17

[www.cnrm.com.mx](http://www.cnrm.com.mx)

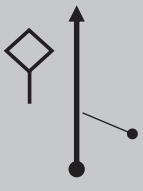

36

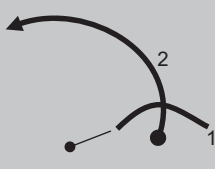
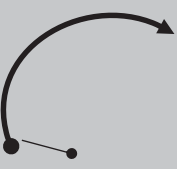
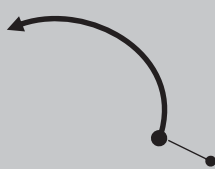
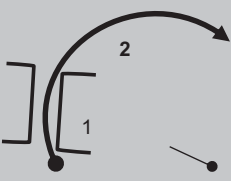
SS TC TC CH	7	LUNATITLÁN 1	DISTANCIA	7	
	8	PLAN SAN MIGUEL	15.520 Km.		
7	LUNATITLÁN 1		9.100 Km.	PROMEDIO-AVERAGE	TIEMPO TIME 00:15
			62 Km/h		

DISTANCIA		DIRECCIÓN DIRECTION	TIERRA	INFORMACIÓN INFORMATION	DIST. REG. TO GO
TOTAL	PARCIAL				
0.000	0.000	 1 9.100	 CONTROL "A" SEÑAL INVERTIDA L.I. N18°09.715' W97°45.175'	15.520	
1.220	1.220	 2 7.880	1 LOMO 2 !!!	14.300	
1.430	0.210	 3 7.670	!!	14.090	
2.120	0.690	 4 6.980	!	13.400	
2.310	0.190	 5 6.790	1 PUENTE ANGOSTO 2 !!!	13.210	

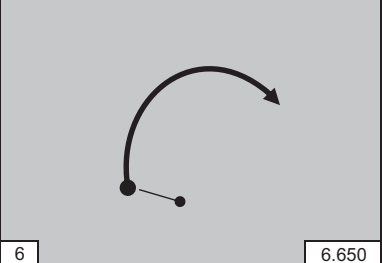

DISTANCIA A LA PRÓXIMA INSTRUCCIÓN	0.140
------------------------------------	-------

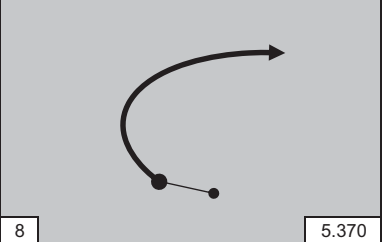
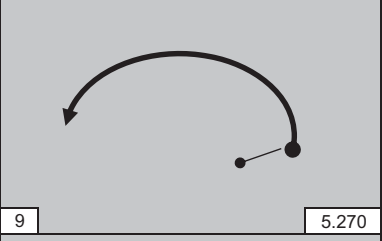
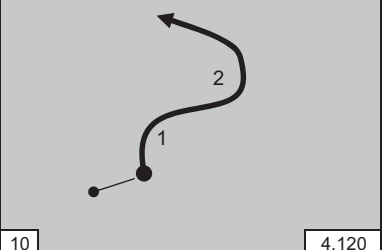
SS	7	LUNATITLÁN 1	DISTANCIA		7
TC			15.520 Km.		
TC	8	PLAN SAN MIGUEL			
CH					
7	LUNATITLÁN 1		9.100 Km.	PROMEDIO-AVERAGE	TIEMPO TIME
				62 Km/h	00:15

DISTANCIA		DIRECCIÓN DIRECTION	TIERRA	INFORMACIÓN INFORMATION	DIST. REG. TO GO
TOTAL	PARCIAL				
2.450	0.140			!!	13.070
3.550	1.100			KM. 6	11.970
3.730	0.180			!!	11.790
3.830	0.100			!	11.690
4.980	1.150			1 ! 2 !!	10.540

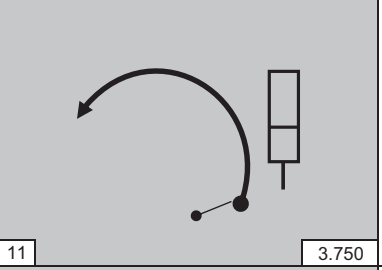
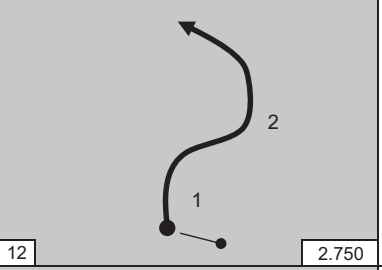
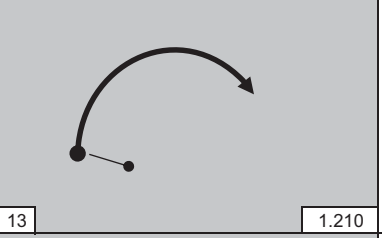
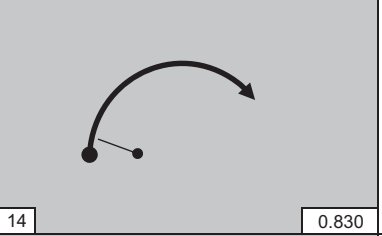
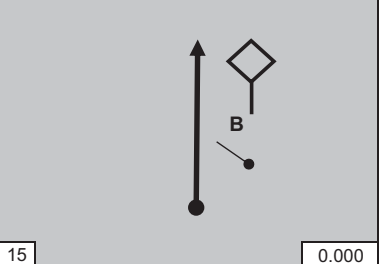

DISTANCIA A LA PRÓXIMA INSTRUCCIÓN	0.370
------------------------------------	-------

SS TC TC CH	7	LUNATITLÁN 1	DISTANCIA	7
	8	PLAN SAN MIGUEL	15.520 Km.	
7	LUNATITLÁN 1		9.100 Km.	PROMEDIO-AVERAGE
			62 Km/h	TIEMPO TIME 00:15

DISTANCIA		DIRECCIÓN DIRECTION	TIERRA	INFORMACIÓN INFORMATION	DIST. REG. TO GO
TOTAL	PARCIAL				
5.350	0.370			!! Y KM. 4	10.170
6.350	1.000			1 !! 2 !	9.170
7.890	1.540			!!	7.630
8.270	0.380			!!	7.250
9.100	0.830			 CONTROL "B"  MARCA EN PISO Y SEÑAL CURVA DER.  N18°10.435' W97°42.139'	6.420

DISTANCIA A LA PRÓXIMA INSTRUCCIÓN	0.350
------------------------------------	-------

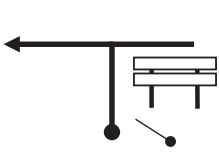
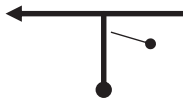
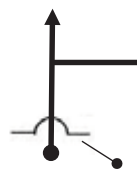
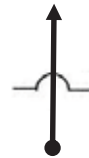



SS TC TC CH	7	LUNATITLÁN 1	DISTANCIA	7	
	8	PLAN SAN MIGUEL	15.520 Km.		
7	LUNATITLÁN 1		9.100 Km.	PROMEDIO-AVERAGE	TIEMPO TIME 00:15
			62 Km/h		

DISTANCIA		DIRECCIÓN DIRECTION	TIERRA	INFORMACIÓN INFORMATION	DIST. REG. TO GO
TOTAL	PARCIAL				
9.450	0.350			<b>STOP</b> CONTROL "C"  LETRERO DOBLE A LA IZQUIERDA	6.070
		18			
11.620	2.170			ENTRONQUE CON CARR. FED. A LA IZQUIERDA	3.900
		19			
13.210	1.590			TOPE Y DE FRENTE	2.310
		18			
13.620	0.410			TOPES (4)	1.900
		19			
14.230	0.610			PEMEX LADO IZQUIERDO SE PERMITE RECARGA	1.290
		20			

DISTANCIA A LA PRÓXIMA INSTRUCCIÓN	1.180
------------------------------------	-------

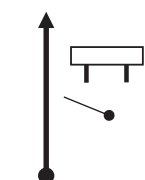

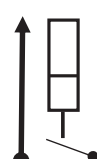
SS TC TC CH	7	LUNATITLÁN 1	DISTANCIA	7	
	8	PLAN SAN MIGUEL	15.520 Km.		
7	LUNATITLÁN 1		9.100 Km.	PROMEDIO-AVERAGE	TIEMPO TIME 00:15
				62 Km/h	

DISTANCIA		DIRECCIÓN DIRECTION	TIERRA	INFORMACIÓN INFORMATION	DIST. REG. TO GO
TOTAL	PARCIAL				
15.410	1.180			 CONTROL "CH" LETRERO "NO DEJE PIEDRAS..."	0.110
		21			
15.520	0.110			 CONTROL "A" KM. 63	0.000
		22			





DISTANCIA A LA PRÓXIMA INSTRUCCIÓN

SS TC CH	8	PLAN SAN MIGUEL	DISTANCIA	8
	9	TRUJAPAN	21.920 Km.	
8	PLAN SAN MIGUEL	8.390 Km.	PROMEDIO-AVERAGE	TIEMPO TIME
			59.8 Km/h	00:22

DISTANCIA		DIRECCIÓN DIRECTION	TIERRA	INFORMACIÓN INFORMATION	DIST. REG. TO GO
TOTAL	PARCIAL				
0.000	0.000			<b>CONTROL "A"</b>  KM. 63  N18°12.046' W97°40.394'	21.920
1.570	1.570			1 !!  2 !!	20.350
3.020	1.450			!!	18.190
3.740	0.720			!!	18.180
5.180	1.440			1 OAXACA  2 !!!	16.740

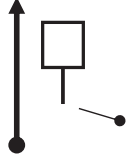

DISTANCIA A LA PRÓXIMA INSTRUCCIÓN	2.100
------------------------------------	-------

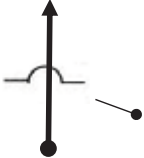
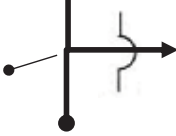
SS TC TC CH	8	PLAN SAN MIGUEL	DISTANCIA	8	
	9	TRUJAPAN	21.920 Km.		
8	PLAN SAN MIGUEL		8.390 Km.	PROMEDIO-AVERAGE	
				59.8 Km/h	TIEMPO TIME 00:22

DISTANCIA		DIRECCIÓN DIRECTION	TIERRA	INFORMACIÓN INFORMATION	DIST. REG. TO GO
TOTAL	PARCIAL				
7.280	2.100	 6 1.110		1 !	14.640
8.390	1.110	 7 0.000		 CONTROL "B" SEÑAL 60 KM/H N18°12.822' W97°37.283'	13.530
8.940	0.550	 8		 CONTROL "C" SEÑAL BUS AZUL	12.980
13.130	4.190	 9		TOPE	8.790
13.270	0.140	 10		A LA DERECHA TOPES (3)	8.650



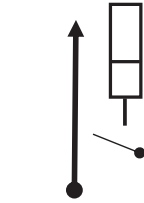
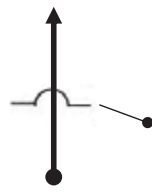
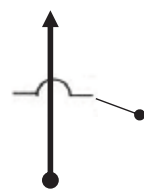
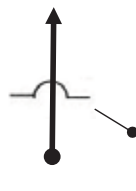

DISTANCIA A LA PRÓXIMA INSTRUCCIÓN	2.170
------------------------------------	-------

SS TC CH	8	PLAN SAN MIGUEL	DISTANCIA	8
	9	TRUJAPAN	21.920 Km.	
8	PLAN SAN MIGUEL	8.390 Km.	PROMEDIO-AVERAGE	TIEMPO TIME
			59.8 Km/h	00:22

DISTANCIA		DIRECCIÓN	TIERRA	INFORMACIÓN INFORMATION	DIST. REG. TO GO
TOTAL	PARCIAL				
15.440	2.170			KM. 2	6.480
		11			
15.640	0.200			TOPE	6.280
		12			
16.160	0.520			TOPE	5.760
		13			
17.150	0.990			TOPES (2)	4.770
		14			
17.450	0.300			KM. 4	4.470
		15			

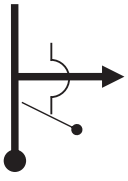
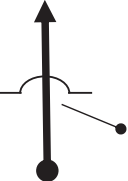
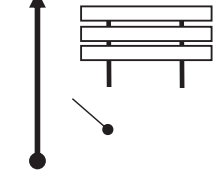

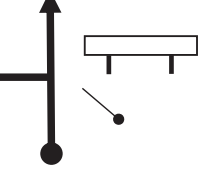
DISTANCIA A LA PRÓXIMA INSTRUCCIÓN	0.060
------------------------------------	-------

SS TC CH	8	PLAN SAN MIGUEL	DISTANCIA		8
	9	TRUJAPAN	21.920 Km.		
8	PLAN SAN MIGUEL		8.390 Km.	PROMEDIO-AVERAGE	TIEMPO TIME
				59.8 Km/h	00:22

DISTANCIA		DIRECCIÓN DIRECTION	TIERRA	INFORMACIÓN INFORMATION	DIST. REG. TO GO
TOTAL	PARCIAL				
17.510	0.060			A LA DERECHA A TRUJAPAN TOPE.	4.410
		16			
17.790	0.280			TOPE	4.130
		17			
21.850	4.060			 CONTROL "CH" LETRERO TRIPLE	0.070
		18			
21.920	0.070			 CONTROL "A" LETRERO SAN PABLO.	0.000
		19			

DISTANCIA A LA PRÓXIMA INSTRUCCIÓN

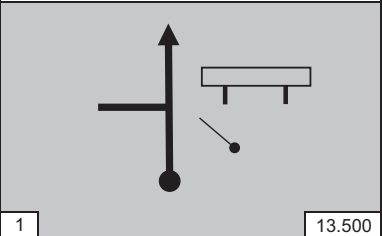
SS TC TC CH	9	TRUJAPAN	DISTANCIA	9	
	9A	SERVICIO 2 EN GASOLINERA CHAZUMBA	18.890 Km.		
9	TRUJAPAN		13.500 Km.	PROMEDIO-AVERAGE	TIEMPO TIME 00:19
				43Km/h	

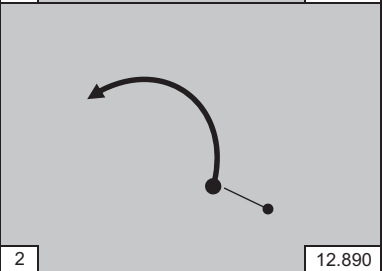
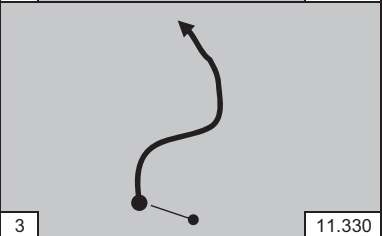
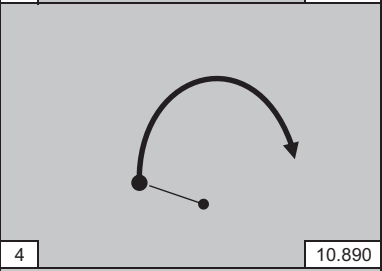
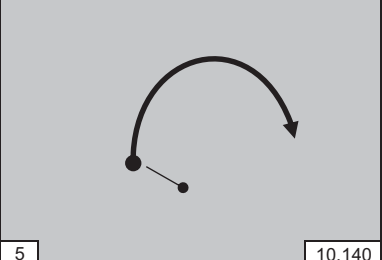
DISTANCIA		DIRECCIÓN DIRECTION	TIERRA	INFORMACIÓN INFORMATION	DIST. REG. TO GO
TOTAL	PARCIAL				
0.000	0.000			 CONTROL "A" LETRERO SAN PABLO.	18.890
0.610	0.610			!!	18.280
2.170	1.560			!!	16.720
2.610	0.440			!!!	16.280
3.360	0.750			!!!	15.530

DISTANCIA A LA PRÓXIMA INSTRUCCIÓN	0.370
------------------------------------	-------

SS TC TC CH	3	TRUJAPAN	DISTANCIA	3	
	4	PLAN SAN MIGUEL	20.200 Km.		
3	TRUJAPAN		13.500 Km.	PROMEDIO-AVERAGE	
				43Km/h	TIEMPO TIME 00:28

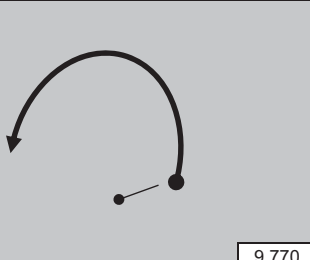
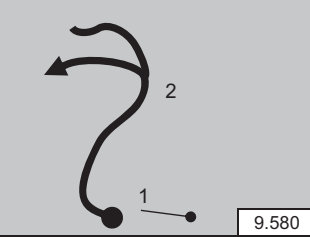
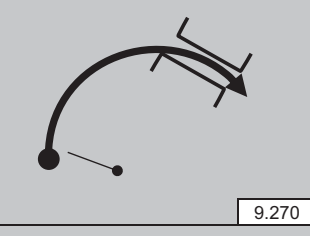
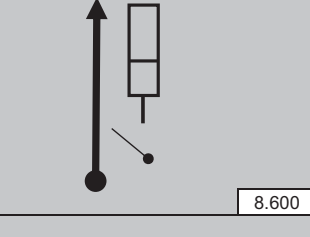
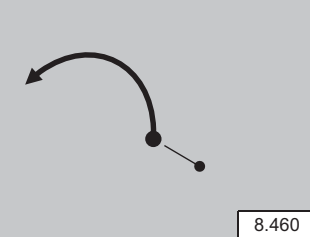
DISTANCIA		DIRECCIÓN DIRECTION	TIERRA	INFORMACIÓN INFORMATION	DIST. REG. TO GO
TOTAL	PARCIAL				
3.730	0.370			!!!	15.160
3.920	0.190			1 !!, 2 !!!	14.970
4.230	0.310			!! Y PUENTE	14.660
4.900	0.670			Km. 13	13.990
5.040	0.140			!!	13.850
DISTANCIA A LA PRÓXIMA INSTRUCCIÓN		1.200			





SS TC TC CH	3	TRUJAPAN	DISTANCIA	3
	4	PLAN SAN MIGUEL	20.200 Km.	
3	TRUJAPAN		13.500 Km.	PROMEDIO-AVERAGE
			43Km/h	TIEMPO TIME 00:28

DISTANCIA		DIRECCIÓN DIRECTION	TIERRA	INFORMACIÓN INFORMATION	DIST. REG. TO GO
TOTAL	PARCIAL				
6.240	1.200			!	12.650
6.500	0.260			1 !!, 2 !!	12.390
6.760	0.260			!!!	12.130
6.900	0.140			Km. 11	11.990
7.400	0.500			!!	11.490

DISTANCIA A LA PRÓXIMA INSTRUCCIÓN	0.770
------------------------------------	-------





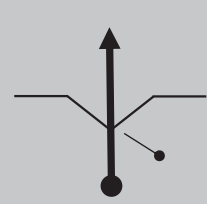

SS TC TC CH	3	TRUJAPAN	DISTANCIA	<b>3</b>	
	4	PLAN SAN MIGUEL	20.200 Km.		
3	TRUJAPAN		13.500 Km.	PROMEDIO-AVERAGE	
				43Km/h	TIEMPO TIME 00:28

DISTANCIA		DIRECCIÓN DIRECTION	TIERRA	INFORMACIÓN INFORMATION	DIST. REG. TO GO
TOTAL	PARCIAL				
8.170	0.770	 16 5.330		!!	10.720
8.910	0.740	 17 4.590		!!	9.980
9.270	0.360	 18 4.230		!!	9.620
10.270	1.000	 19 3.230		!!	8.620
11.380	1.110	 20 2.120		!!	7.510

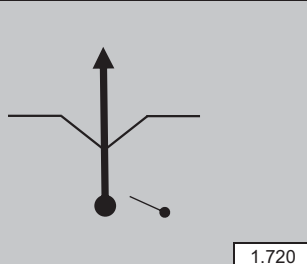
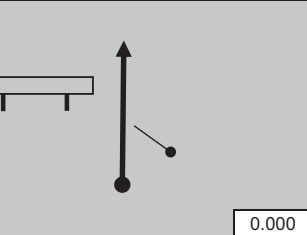

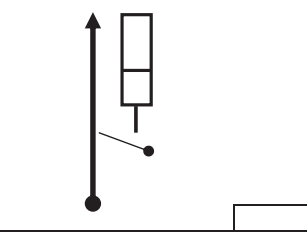
DISTANCIA A LA PRÓXIMA INSTRUCCIÓN	0.400
------------------------------------	-------

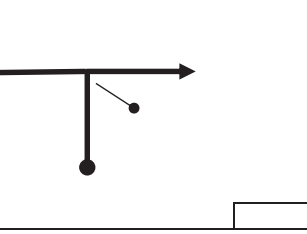
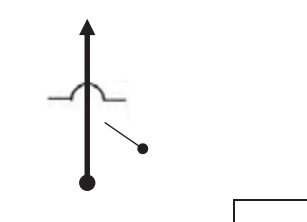
SS TC TC CH	3	TRUJAPAN	DISTANCIA	3	
	4	PLAN SAN MIGUEL	20.200 Km.		
3	TRUJAPAN		13.500 Km.	PROMEDIO-AVERAGE	
				43Km/h	TIEMPO TIME 00:28

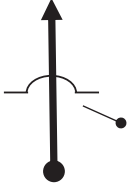

DISTANCIA		DIRECCIÓN DIRECTION	TIERRA	INFORMACIÓN INFORMATION	DIST. REG. TO GO
TOTAL	PARCIAL				
11.780	0.400	 21 1.720		!	7.110
13.500	1.720	 22 0.000		<b>CONTROL "B"</b> LETRERO INV. SAN J. TRUJAPAN N18°12.187' W97°32.949'	5.390
13.940	0.440	 23		<b>CONTROL "C"</b> KM. 4	4.950
17.920	3.980	 24		A LA DERECHA	0.970
18.300	0.380	 25		TOPES (2)	0.590

DISTANCIA A LA PRÓXIMA INSTRUCCIÓN	0.610
------------------------------------	-------

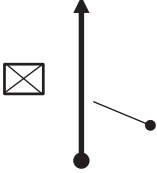
SS TC TC CH	3	TRUJAPAN	DISTANCIA	3	
	4	PLAN SAN MIGUEL	20.200 Km.		
3	TRUJAPAN		13.500 Km.	PROMEDIO-AVERAGE	TIEMPO TIME 00:28
				43Km/h	



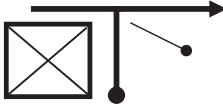
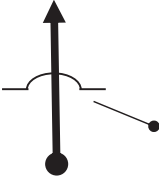
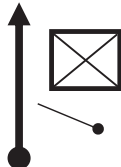

DISTANCIA		DIRECCIÓN DIRECTION	TIERRA	INFORMACIÓN INFORMATION	DIST. REG. TO GO
TOTAL	PARCIAL				
18.860	0.560			 <b>CONTROL "CH"</b>  <b>ENTRADA A SERVICIO EN TOPE.</b>	0.030
		26			
18.890	0.030			<b>PEMEX LADO IZQUIERDO</b>  <b>AREA DE SERVICIO</b>	0.000
		27			

TC CH TC CH	9A	SERVICIO EN GASOLINERA CHAZUMBA	DISTANCIA	9A
	9B	ENTRADA A RECLASIFICACION	0.320 Km.	
			PROMEDIO-AVERAGE	01:00

DISTANCIA		DIRECCIÓN DIRECTION	TIERRA	INFORMACIÓN INFORMATION	DIST. REG. TO GO
TOTAL	PARCIAL				
0.000	0.000			SALIDA DE GASOLINERA	0.320
		1			
0.030	0.030			TOPES (2)	0.290
		2			
0.320	0.290			 CONTROL "CH" ENTRADA A RECLASIFICACIÓN GASOLINERA ABANDONADA	0.000
		3			

DISTANCIA A LA PRÓXIMA INSTRUCCIÓN

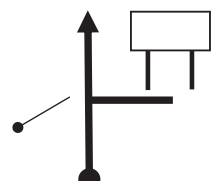
TC CH TC CH	9B	ENTRADA A RECLASIFICACION	DISTANCIA	<b>9B</b>
	9C	SALIDA DE RECLASIFICACION	0.110 Km.	
			PROMEDIO-AVERAGE	00:15

DISTANCIA		DIRECCIÓN DIRECTION	TIERRA	INFORMACIÓN INFORMATION	DIST. REG. TO GO
TOTAL	PARCIAL				
0.000	0.000			 <b>CONTROL "CH"</b>  ENTRADA A RECLASIFICACIÓN GASOLINERA ABANDONADA	0.110
		1			
0.110	0.110			 <b>CONTROL "CH"</b>  SALIDA DE RECLASIFICACIÓN LETRERO "SASCH"	0.000
		2			



DISTANCIA A LA PRÓXIMA INSTRUCCIÓN

51° RALLY MEDIA NOCHE

jmgf-2017

[www.cnrm.com.mx](http://www.cnrm.com.mx)

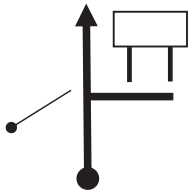
TC CH TC CH	9C	SALIDA DE RECLASIFICACION	DISTANCIA	9C
	10	JOLUXTLA 1	3.780 Km.	
			PROMEDIO-AVERAGE	TIEMPO TIME 00:05
			45.4 Km/h.	

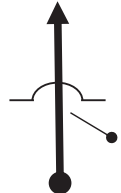
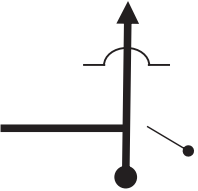
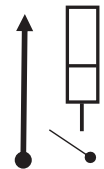
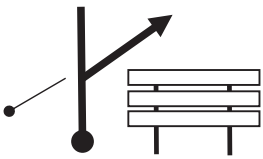
DISTANCIA		DIRECCIÓN DIRECTION	TIERRA	INFORMACIÓN INFORMATION	DIST. REG. TO GO
TOTAL	PARCIAL				
0.000	0.000			 CONTROL "CH"  SALIDA DE RECLASIFICACION LETRERO "SASCH"	
		1			
0.150	0.150			TOPE	
		2			
0.530	0.380			DE FRENTE, TOPE	
		3			
1.230	0.700			KM. 66	
		4			
1.390	0.160			A LA DERECHA LETRERO TRIPLE.	
		5			





51° RALLY MEDIA NOCHE

jmgf-17

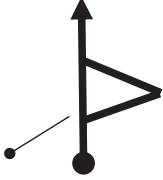
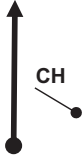

[www.cnrm.com.mx](http://www.cnrm.com.mx)

DISTANCIA A LA PRÓXIMA INSTRUCCIÓN	2.230
------------------------------------	-------

TC CH TC CH	5C	SALIDA DE RECLASIFICACION	DISTANCIA	5C
	6	JOLUXTLA 1	3.780 Km.	
			PROMEDIO-AVERAGE	TIEMPO TIME 00:05
			45.4 Km/h.	

DISTANCIA		DIRECCIÓN DIRECCION	TIERRA	INFORMACIÓN INFORMATION	DIST. REG. TO GO
TOTAL	PARCIAL				
3.620	2.230			ENTRONQUE DE FRENTE.	
3.730	0.110			 CONTROL "CH"  MARCA EN PISO.	
3.780	0.050			 CONTROL "A"  MARCA EN PISO Y CUNETETA.	

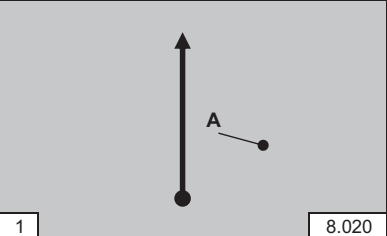
SS TC CH	10	JOLUXTLA 2	DISTANCIA	10	
	11	LUNATITLÁN 2	9.630 Km.		
10	JOLUXTLA 2		8.020 Km.	PROMEDIO-AVERAGE	
				58 Km/h	TIEMPO TIME 00:10

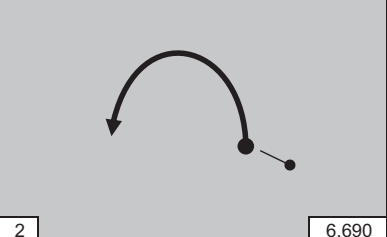
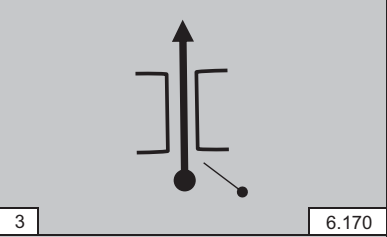
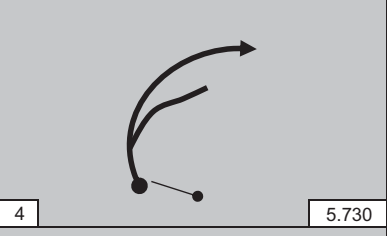
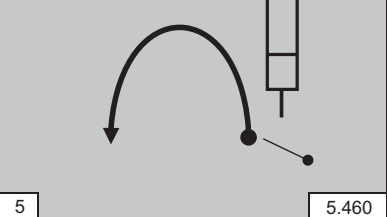
DISTANCIA		DIRECCIÓN DIRECTION	TIERRA	INFORMACIÓN INFORMATION	DIST. REG. TO GO
TOTAL	PARCIAL				
0.000	0.000			 <p><b>CONTROL "A"</b> <b>MARCA EN PISO</b></p> <p>N18°10.248' W97°41.928'</p>	9.630
1.330	1.330			!!!	8.300
1.850	0.520			PUENTE	7.780
2.290	0.440			POR CARRIL IZQUIERDO ENTRONQUE HUAXTEPEC !!	7.340
2.560	0.270			Km. 5 !!!	7.070

DISTANCIA A LA PRÓXIMA INSTRUCCIÓN	0.150
------------------------------------	-------





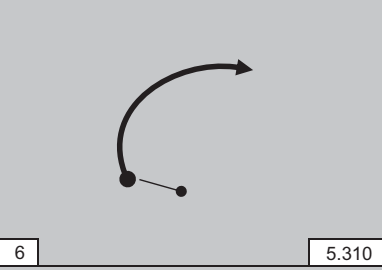
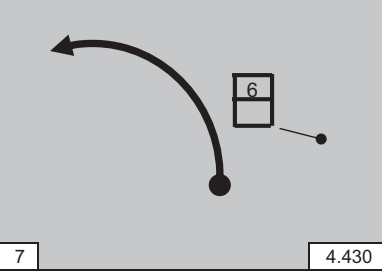
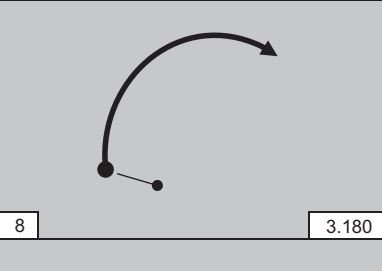
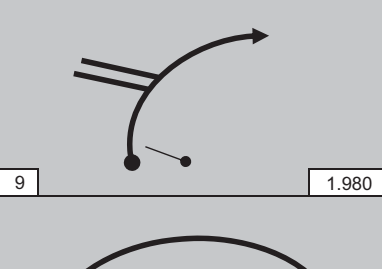
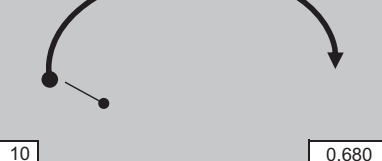

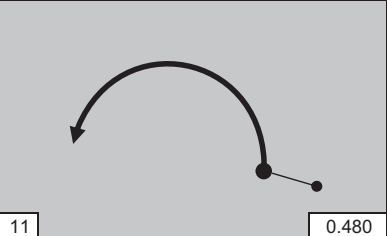
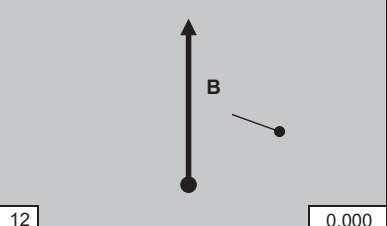

SS TC TC CH	10	JOLUXTLA 2	DISTANCIA	10
	11	LUNATITLÁN 2	9.630 Km.	
10	JOLUXTLA 2	8.020 Km.	PROMEDIO-AVERAGE	TIEMPO TIME
			58 Km/h	00:10

DISTANCIA		DIRECCIÓN DIRECTION	TIERRA	INFORMACIÓN INFORMATION	DIST. REG. TO GO
TOTAL	PARCIAL				
2.710	0.150			!!	6.920
3.590	0.880				6.040
4.840	1.250			!!	4.790
6.040	1.200			ENTRONQUE ACAQUIZAPAN !	3.590
7.340	1.300			DERECHA LARGA. !	2.290

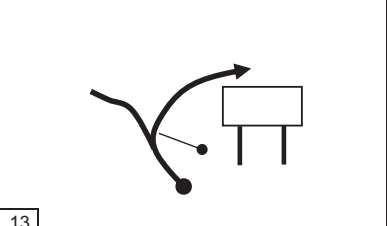

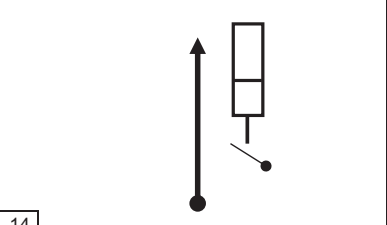
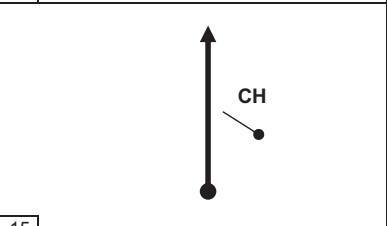
DISTANCIA A LA PRÓXIMA INSTRUCCIÓN	0.200
------------------------------------	-------

SS TC TC CH	10	JOLUXTLA 2	DISTANCIA		10
	11	LUNATITLÁN 2	9.630 Km.		
10	JOLUXTLA 2		8.020 Km.	PROMEDIO-AVERAGE	TIEMPO TIME 00:10
				58 Km/h	

DISTANCIA		DIRECCIÓN	TIERRA	INFORMACIÓN INFORMATION	DIST. REG. TO GO
TOTAL	PARCIAL				
7.540	0.200			!! Y KM. 10	2.090
8.020	0.480			 CONTROL "B" MARCA EN PISO Y ROCA L.D.  N18°09.247' W97°44.447'	1.610
8.350	0.330			 CONTROL "C"  EN ENTRONQUE Y LETRERO MOVER A MEXICO	1.280
8.950	0.600			KM. 10	0.680
9.570	0.620			 CONTROL "CH"  MARCA EN PISO Y CASA L.I.	0.060

DISTANCIA A LA PRÓXIMA INSTRUCCIÓN	0.060
------------------------------------	-------

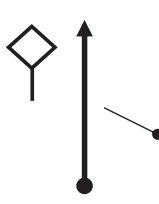
SS TC CH	10	JOLUXTLA 2	DISTANCIA		10
	11	LUNATITLÁN 2	9.630 Km.		
10	JOLUXTLA 2		8.020 Km.	PROMEDIO-AVERAGE	TIEMPO TIME 00:10
				58 Km/h	

DISTANCIA		DIRECCIÓN DIRECTION	TIERRA	INFORMACIÓN INFORMATION	DIST. REG. TO GO
TOTAL	PARCIAL				
9.630	0.060			 <b>CONTROL "A"</b>  <b>SEÑAL INVERTIDA</b> <b>LADO IZQUIERDO</b>	0,000
		16			

DISTANCIA A LA PRÓXIMA INSTRUCCIÓN



51° RALLY MEDIA NOCHE

jmgf-17

[www.cnrm.com.mx](http://www.cnrm.com.mx)

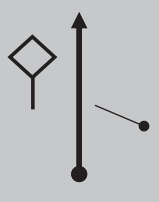

59

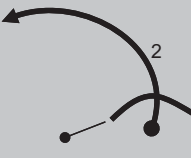
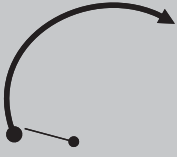
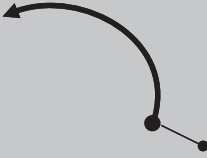
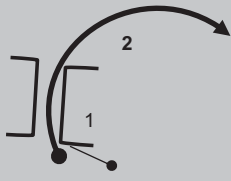
SS TC TC CH	11	LUNATITLÁN 2	DISTANCIA	11	
	12	ATZUMBA	17.650 Km.		
11	LUNATITLÁN		9.100 Km.	PROMEDIO-AVERAGE	
				58.8 Km/h	TIEMPO TIME 00:18

DISTANCIA		DIRECCIÓN DIRECTION	TIERRA	INFORMACIÓN INFORMATION	DIST. REG. TO GO
TOTAL	PARCIAL				
0.000	0.000			 <b>CONTROL "A"</b>  SEÑAL INVERTIDA L.I. N18°09.715' W97°45.175'	15.520
		1 9.100			
1.220	1.220			1 LOMO  2 !!!	14.300
		2 7.880			
1.430	0.210			!!	14.090
		3 7.670			
2.120	0.690			!	13.400
		4 6.980			
2.310	0.190			1 PUENTE ANGOSTO  2 !!!	13.210
		5 6.790			

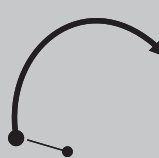
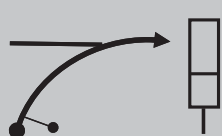
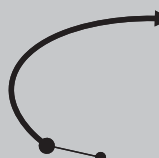

DISTANCIA A LA PRÓXIMA INSTRUCCIÓN	0.140
------------------------------------	-------

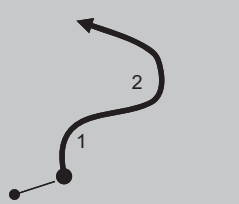
SS TC TC CH	11	LUNATITLÁN 2	DISTANCIA	<b>11</b>	
	12	ATZUMBA	17.650 Km.		
11	LUNATITLÁN		9.100 Km.	PROMEDIO-AVERAGE	
				58.8 Km/h	TIEMPO TIME 00:18

DISTANCIA		DIRECCIÓN DIRECTION	TIERRA	INFORMACIÓN INFORMATION	DIST. REG. TO GO
TOTAL	PARCIAL				
2.450	0.140	 6 6.650		!!	13.070
3.550	1.100	 7 5.550		KM. 6	11.970
3.730	0.180	 8 5.370		!!	11.790
3.830	0.100	 9 5.270		!	11.690
4.980	1.150	 10 4.120		1 ! 2 !!	10.540



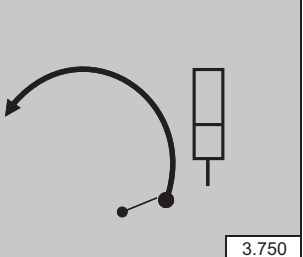
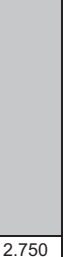

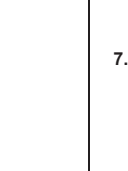
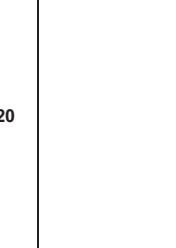

DISTANCIA A LA PRÓXIMA INSTRUCCIÓN	0.370
------------------------------------	-------

SS TC TC CH	11	LUNATITLÁN 2	DISTANCIA	11	
	12	ATZUMBA	17.650 Km.		
11	LUNATITLÁN		9.100 Km.	PROMEDIO-AVERAGE	
				58.8 Km/h	TIEMPO TIME 00:18

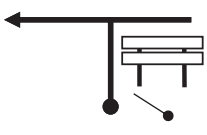
DISTANCIA		DIRECCIÓN DIRECTION	TIERRA	INFORMACIÓN INFORMATION	DIST. REG. TO GO
TOTAL	PARCIAL				
5.350	0.370			!! Y KM. 4	10.170
		11 3.750			
6.350	1.000			1 !! 2 !	9.170
		12 2.750			
7.890	1.540			!!	7.630
		13 1.210			
8.270	0.380			!!	7.250
		14 0.830			
9.100	0.830			CONTROL "B"  MARCA EN PISO Y SEÑAL CURVA DER.  N18°10.435' W97°42.139'	6.420
		15 0.000			

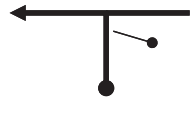
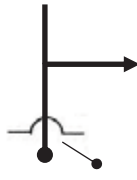

DISTANCIA A LA PRÓXIMA INSTRUCCIÓN	0.350
------------------------------------	-------

SS TC TC CH	11	LUNATITLÁN 2	DISTANCIA		11
	12	ATZUMBA	17.650 Km.		
11	LUNATITLÁN		9.100 Km.	PROMEDIO-AVERAGE	TIEMPO TIME 00:18
				58.8 Km/h	

DISTANCIA		DIRECCIÓN DIRECTION	TIERRA	INFORMACIÓN INFORMATION	DIST. REG. TO GO
TOTAL	PARCIAL				
9.450	0.350			 CONTROL "C"  LETRERO DOBLE A LA IZQUIERDA	6.070
11.620	2.170			ENTRONQUE CON CARR. FED. A LA IZQUIERDA	3.900
13.210	1.590			A LA DERECHA A TRUJAPAN	4.440
16.190	2.980			KM. 3	1.460
17.480	1.290			 CONTROL "CH"  SEÑAL LADO DERECHO.	0.170

DISTANCIA A LA PRÓXIMA INSTRUCCIÓN	0.170
------------------------------------	-------

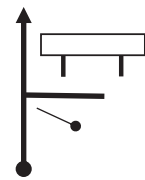
SS TC TC CH	11	LUNATITLÁN 2	DISTANCIA		11
	12	ATZUMBA	17.650 Km.		
11	LUNATITLÁN		9.100 Km.	PROMEDIO-AVERAGE	TIEMPO TIME
				58.8 Km/h	00:18

DISTANCIA		DIRECCIÓN DIRECTION	TIERRA	INFORMACIÓN INFORMATION	DIST. REG. TO GO
TOTAL	PARCIAL				
17.650	0.170			 CONTROL "A"  LETRERO SAN J. TRUJAPAN.	0.000
	21				





51° RALLY MEDIA NOCHE

jmgf-17

[www.cnrn.com.mx](http://www.cnrn.com.mx)

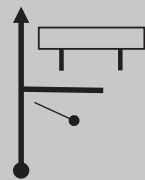

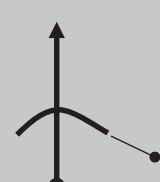
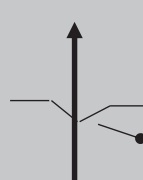
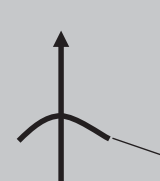
SS TC TC CH	12	ATZUMBA	DISTANCIA	12	
	13	COL SAN MARTÍN	22.660 Km.		
12	ATZUMBA		17.280 Km	PROMEDIO-AVERAGE	TIEMPO TIME 00:22
				61.8 Km/h	



DISTANCIA		DIRECCIÓN DIRECTION	TIERRA	INFORMACIÓN INFORMATION	DIST. REG. TO GO
TOTAL	PARCIAL				
0.000	0.000	 1 17.280		 CONTROL "A"  LETRERO SAN J. TRUJAPAN. N 18° 10.216' W 97° 38.700'	22.660
1.540	1.540	 2 15.740		LOMO	21.120
2.100	0.560	 3 15.180		!!	20.560
2.900	0.800	 4 14.380		LOMO	19.760
3.180	0.280	 5 14.100		!!	19.480

DISTANCIA A LA PRÓXIMA INSTRUCCIÓN	1.010
------------------------------------	-------

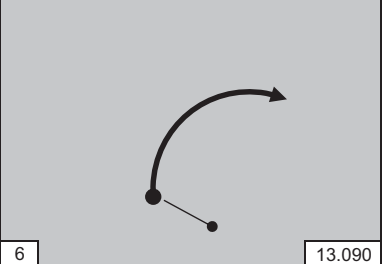
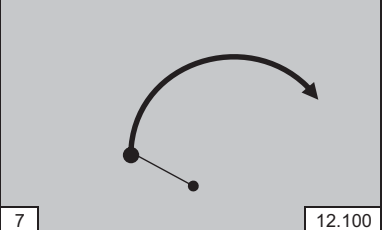
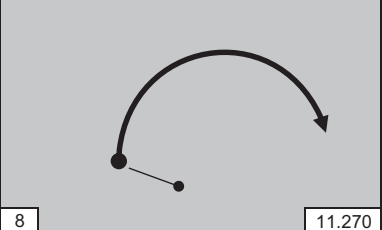
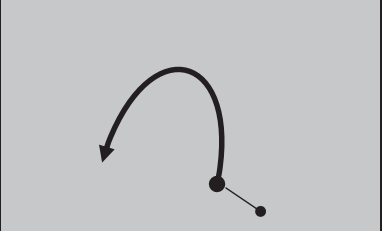
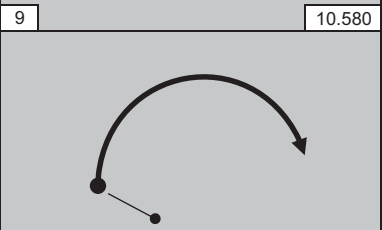
SS TC TC CH	12	ATZUMBA	DISTANCIA		12
	13	COL SAN MARTÍN	22.660 Km.		
12	ATZUMBA		17.280 Km	PROMEDIO-AVERAGE	
				61.8 Km/h	TIEMPO TIME 00:22

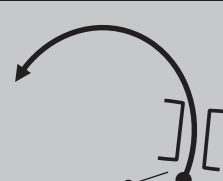
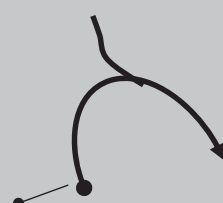

DISTANCIA		DIRECCIÓN DIRECTION	TIERRA	INFORMACIÓN INFORMATION	DIST. REG. TO GO
TOTAL	PARCIAL				
4.190	1.010			!	18.470
5.180	0.990			!!	17.480
6.010	0.830			!!	16.650
6.700	0.690			!!!	15.960
7.220	0.520			!!	15.440
DISTANCIA A LA PRÓXIMA INSTRUCCIÓN		1.180			

SS TC TC CH	12	ATZUMBA	DISTANCIA		12
	13	COL SAN MARTÍN	22.660 Km.		
12	ATZUMBA		17.280 Km	PROMEDIO-AVERAGE	
				61.8 Km/h	TIEMPO TIME 00:22

DISTANCIA		DIRECCIÓN DIRECTION	TIERRA	INFORMACIÓN INFORMATION	DIST. REG. TO GO
TOTAL	PARCIAL				
8.400	1.180	 11 8.880		!!	14.260
9.170	0.770	 12 8.110		PUENTE Y !!	13.490
9.350	0.180	 13 7.930		!!!	13.310
10.400	1.050	 14 6.880		! LARGA	12.260
10.700	0.300	 15 6.580		LARGA	11.960



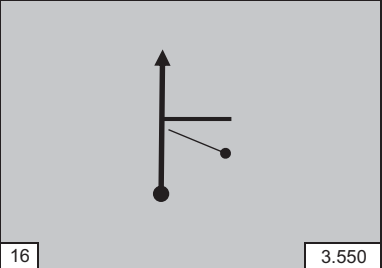
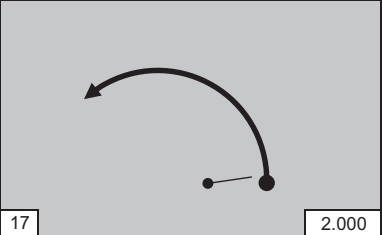
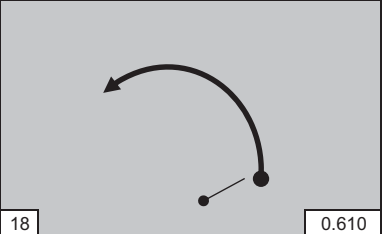
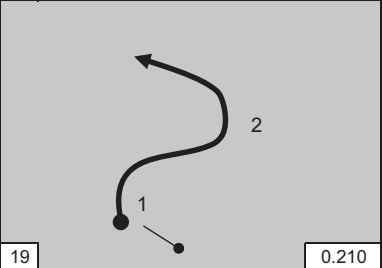
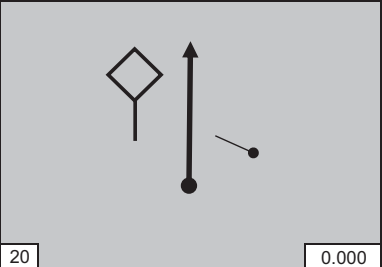

DISTANCIA A LA PRÓXIMA INSTRUCCIÓN	3.030
------------------------------------	-------

SS TC TC CH	12	ATZUMBA	DISTANCIA	12	
	13	COL SAN MARTÍN	22.660 Km.		
12	ATZUMBA		17.280 Km	PROMEDIO-AVERAGE	TIEMPO TIME 00:22
				61.8 Km/h	

DISTANCIA		DIRECCIÓN DIRECTION	TIERRA	INFORMACIÓN INFORMATION	DIST. REG. TO GO
TOTAL	PARCIAL				
13.730	3.030	 16 3.550		DE FRENTE	8.930
15.280	1.550	 17 2.000		!	7.380
16.670	1.390	 18 0.610		!	5.990
17.070	0.400	 19 0.210		1 ! 2 !!	5.590
17.280	0.210	 20 0.000		 CONTROL "B"  SEÑAL INVERTIDA LADO IZQUIERDO  N18°12.055' W97°33.390'	5.380

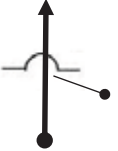



DISTANCIA A LA PRÓXIMA INSTRUCCIÓN	0.300
------------------------------------	-------

SS TC TC CH	12	ATZUMBA	DISTANCIA	12	
	13	COL SAN MARTÍN	22.660 Km.		
12	ATZUMBA		17.280 Km	PROMEDIO-AVERAGE	TIEMPO TIME 00:22
				61.8 Km/h	

DISTANCIA		DIRECCIÓN DIRECTION	TIERRA	INFORMACIÓN INFORMATION	DIST. REG. TO GO
TOTAL	PARCIAL				
17.580	0.300			<b>STOP</b> CONTROL "C"  TOPES (2)	5.080
17.840	0.260			A LA DERECHA Y TOPE.	4.820
17.930	0.090			TOPES (2)	4.730
19.220	1.290			TOPE	3.440
19.740	0.520			TOPE	2.920

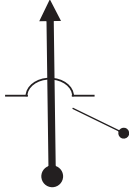
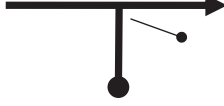
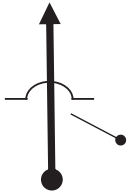
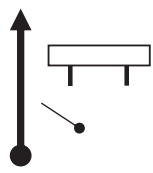



DISTANCIA A LA PRÓXIMA INSTRUCCIÓN	2.120
------------------------------------	-------

SS TC TC CH	12	ATZUMBA	DISTANCIA	12	
	13	COL SAN MARTÍN	22.660 Km.		
12	ATZUMBA		17.280 Km	PROMEDIO-AVERAGE	TIEMPO TIME 00:22
				61.8 Km/h	

DISTANCIA		DIRECCIÓN DIRECTION	TIERRA	INFORMACIÓN INFORMATION	DIST. REG. TO GO
TOTAL	PARCIAL				
21.860	2.120			TOPES (3)	0.800
		26			
22.090	0.230			A LA DERECHA POR CARRETERA FEDERAL.	0.570
		27			
22.200	0.110			TOPES (2)	0.460
		28			
22.600	0.400			 CONTROL "CH"  LETRERO "CONCEDA..."	0.060
		29			
22.660	0.060			 CONTROL "A"  SEÑAL "PENDIENTE" LADO DERECHO.	0.000
		30			

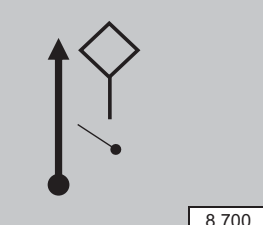

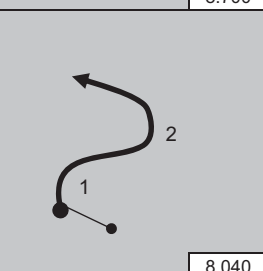
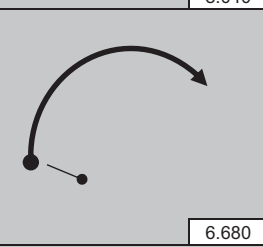
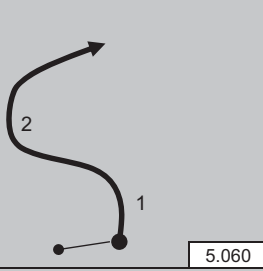

DISTANCIA A LA PRÓXIMA INSTRUCCIÓN

SS TC TC CH	13	COL. SAN MARTÍN	DISTANCIA	<b>13</b>
	14	ZORRILLO 2	21.300 Km.	
13	COL. SAN MARTÍN		8.700 Km.	PROMEDIO-AVERAGE
			60.9 Km/h	TIEMPO TIME 00:21

DISTANCIA		DIRECCIÓN DIRECTION	TIERRA	INFORMACIÓN INFORMATION	DIST. REG. TO GO
TOTAL	PARCIAL				
0.000	0.000	 1 8.700		 CONTROL "A"  SEÑAL "PENDIENTE"  N18°13.969' w 97° 34.718'	21.300
0.660	0.660	 2 8.040		1 !  2 !!	20.640
2.020	1.360	 3 6.680		!!	19.280
3.640	1.620	 4 5.060		1 !  2 !! LARGA	17.660
4.420	0.780	 5 4.280		!!!	16.880

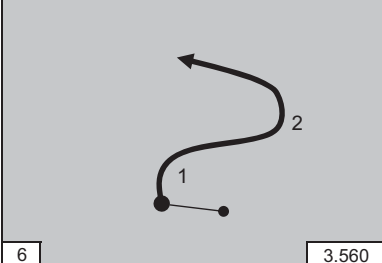
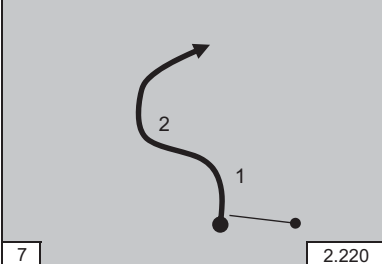
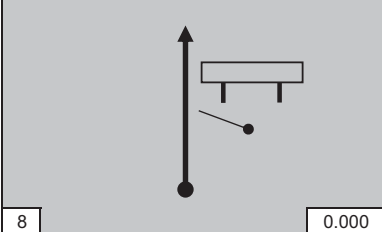
DISTANCIA A LA PRÓXIMA INSTRUCCIÓN	0.720
------------------------------------	-------

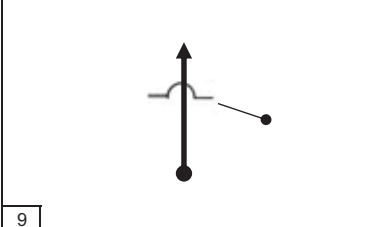

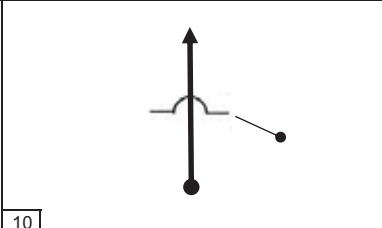



SS TC TC CH	13	COL. SAN MARTÍN	DISTANCIA		<b>13</b>
	14	ZORRILLO 2	21.300 Km.		
13	COL. SAN MARTÍN		8.700 Km.	PROMEDIO-AVERAGE	TIEMPO TIME <b>00:21</b>
				60.9 Km/h	

DISTANCIA		DIRECCIÓN DIRECCION	TIERRA	INFORMACIÓN INFORMATION	DIST. REG. TO GO
TOTAL	PARCIAL				
5.140	0.720			1 !! 2 !!	16.160
6.480	1.340			1 ! 2 !!	14.820
8.700	2.220			 CONTROL "B" LETRERO OBEDEZCA... N18°16.209' W97°32.539'	12.600
9.520	0.820			 CONTROL "C" EN TOPE	11.780
9.740	0.220			TOPES (2)	11.560

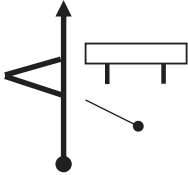
DISTANCIA A LA PRÓXIMA INSTRUCCIÓN	4.070
------------------------------------	-------

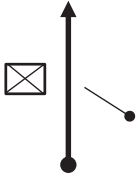
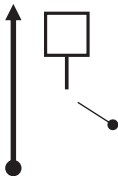



SS TC TC CH	13	COL. SAN MARTÍN	DISTANCIA		13
	14	ZORRILLO 2	21.300 Km.		
13	COL. SAN MARTÍN		8.700 Km.	PROMEDIO-AVERAGE	TIEMPO TIME 00:21
				60.9 Km/h	

DISTANCIA		DIRECCIÓN DIRECTION	TIERRA	INFORMACIÓN INFORMATION	DIST. REG. TO GO
TOTAL	PARCIAL				
13.810	4.070			DE FRENTE STA. ANA TELOXTOC	7.490
		11			
19.320	5.510			TOPES (5)	1.980
		12			
20.650	1.330			PEMEX LADO IZQUIERDO	0.650
		13			
11.040	2.170			 CONTROL "CH" SEÑAL CINTURON DE SEGURIDAD	2.660
		14			
11.240	0.200			 CONTROL "A" KM. 26	2.460
		15			



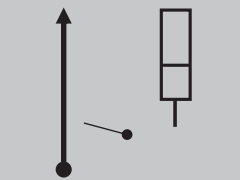

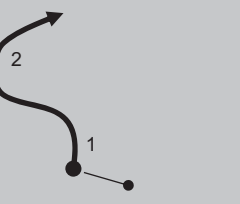
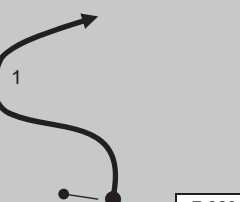
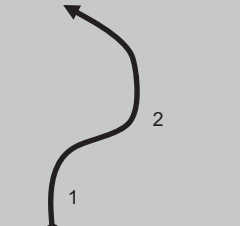
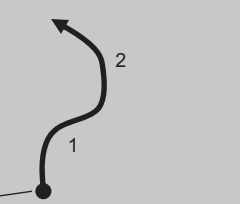
DISTANCIA A LA PRÓXIMA INSTRUCCIÓN	0.000
------------------------------------	-------

SS TC TC CH	14	EL ZORRILLO 2	DISTANCIA	14	
	14A	META EN WALMART TEHUACÁN	23.520 Km.		
14	EL ZORRILLO 2		9.840 Km.	PROMEDIO-AVERAGE	
				58.8 Km/h	TIEMPO TIME 00:24

DISTANCIA		DIRECCIÓN DIRECTION	TIERRA	INFORMACIÓN INFORMATION	DIST. REG. TO GO
TOTAL	PARCIAL				
0.000	0.000			 <b>CONTROL "A"</b>  KM. 26  N18°20.044' W97°27.669'	23.520
		1	9.840		
0.520	0.520			1 !  2 !!	23.000
		2	9.320		
2.180	1.660			1 !!	21.340
		3	7.660		
2.560	0.380			1 !!  2 !	20.960
		4	7.280		
4.500	1.940			1 !!  2 !	19.020
		5	5.340		

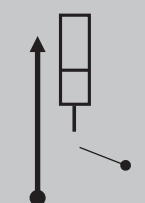



DISTANCIA A LA PRÓXIMA INSTRUCCIÓN 1.590

SS TC TC CH	14	EL ZORRILLO 2	DISTANCIA		14
	14A	META EN WALMART TEHUACÁN	23.520 Km.		
14	EL ZORRILLO 2		9.840 Km.	PROMEDIO-AVERAGE	TIEMPO TIME
				58.8 Km/h	00:24

DISTANCIA		DIRECCIÓN DIRECTION	TIERRA	INFORMACIÓN INFORMATION	DIST. REG. TO GO
TOTAL	PARCIAL				
6.090	1.590			KM. 20	17.430
		6 3.750			
6.990	0.900			1 !!! 2 !!!	16.530
		7 2.850			
8.220	1.230			!	15.300
		8 1.620			
8.680	0.460			1 ! 2 !	14.840
		9 1.160			
9.600	0.920			1 !! 2 !!	13.920
		10 0.240			

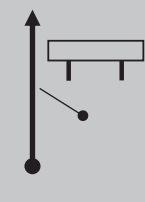
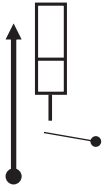
DISTANCIA A LA PRÓXIMA INSTRUCCIÓN	0.240
------------------------------------	-------

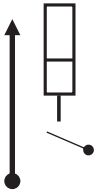
SS TC TC CH	14	EL ZORRILLO 2	DISTANCIA	14
	14A	META EN WALMART TEHUACÁN	23.520 Km.	
14	EL ZORRILLO 2		9.840 Km.	PROMEDIO-AVERAGE
			58.8 Km/h	TIEMPO TIME 00:24

DISTANCIA		DIRECCIÓN DIRECTION	TIERRA	INFORMACIÓN INFORMATION	DIST. REG. TO GO
TOTAL	PARCIAL				
9.840	0.240			<b>CONTROL "B"</b>  MARCA EN PISO LETRERO LADO DERECHO  N18°23.402' W97°26.560'	13.680
10.150	0.310			<b>CONTROL "C"</b>  KM. 16	13.370
10.480	0.330			TOPES (4)	13.040
16.240	5.760			KM. 10	7.280
17.490	1.250			POR LA DERECHA	6.030



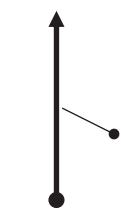
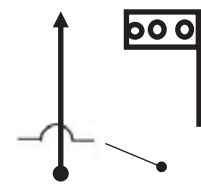
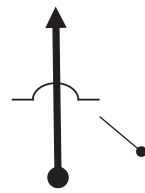
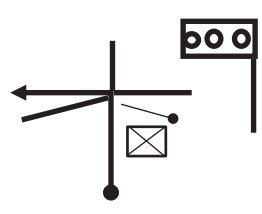
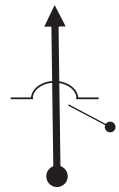

DISTANCIA A LA PRÓXIMA INSTRUCCIÓN	0.490
------------------------------------	-------

SS TC TC CH	14	EL ZORRILLO 2	DISTANCIA	14	
	14A	META EN WALMART TEHUACÁN	23.520 Km.		
14	EL ZORRILLO 2		9.840 Km.	PROMEDIO-AVERAGE	
				58.8 Km/h	TIEMPO TIME 00:24

DISTANCIA		DIRECCIÓN DIRECTION	TIERRA	INFORMACIÓN INFORMATION	DIST. REG. TO GO
TOTAL	PARCIAL				
17.980	0.490			TEHUACAN	5.540
		16			
18.350	0.370			TOPE Y SEMÁFORO	5.170
		17			
18.590	0.240			TOPES (4)	4.930
		18			
19.760	1.170			A LA IZQUIERDA POR LIBRAMIENTO (I. TECNOLÓGICO DE TEH.)	3.760
		19			
20.080	0.320			TOPE	3.440
		20			

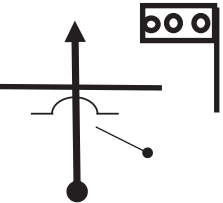
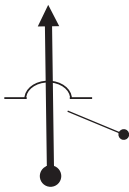

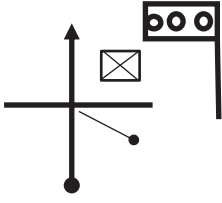

DISTANCIA A LA PRÓXIMA INSTRUCCIÓN	0.440
------------------------------------	-------

SS TC TC CH	14	EL ZORRILLO 2	DISTANCIA	14	
	14A	META EN WALMART TEHUACÁN	23.520 Km.		
14	EL ZORRILLO 2		9.840 Km.	PROMEDIO-AVERAGE	
				58.8 Km/h	TIEMPO TIME 00:24

DISTANCIA		DIRECCIÓN DIRECTION	TIERRA	INFORMACIÓN INFORMATION	DIST. REG. TO GO
TOTAL	PARCIAL				
20.610	0.530			TOPE Y SEMÁFORO	2.910
		21			
21.270	0.660			TOPES (2)	2.250
		22			
21.670	0.400			SEMÁFORO A LA DERECHA CALLE 17 ORIENTE	1.850
		23			
22.130	0.460			SEMÁFORO DE FRENTE (PEMEX)	1.390
		24			
22.310	0.180			TOPE	1.210
		25			

DISTANCIA A LA PRÓXIMA INSTRUCCIÓN	0.220
------------------------------------	-------

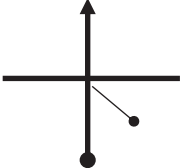
SS TC TC CH	14	EL ZORRILLO 2	DISTANCIA		14
	14A	META EN WALMART TEHUACÁN	23.520 Km.		
14	EL ZORRILLO 2		9.840 Km.	PROMEDIO-AVERAGE	TIEMPO TIME
				58.8 Km/h	00:24

DISTANCIA		DIRECCIÓN DIRECTION	TIERRA	INFORMACIÓN INFORMATION	DIST. REG. TO GO
TOTAL	PARCIAL				
22.530	0.220			TOPE	0.990
		21			
22.680	0.150			A LA DERECHA POR CALLE BENITO JUÁREZ.	0.840
		22			
22.810	0.130			DE FRENTE PRECAUCIÓN	0.790
		23			
22.970	0.160			TOPES (2)	
		24			
23.210	0.240			TOPE	
		25			

DISTANCIA A LA PRÓXIMA INSTRUCCIÓN	0.250
------------------------------------	-------

SS TC TC CH	14	EL ZORRILLO 2	DISTANCIA	14	
	14A	META EN WALMART TEHUACÁN	23.520 Km.		
14	EL ZORRILLO 2		9.840 Km.	PROMEDIO-AVERAGE	
				58.8 Km/h	TIEMPO TIME 00:24

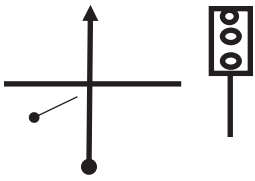
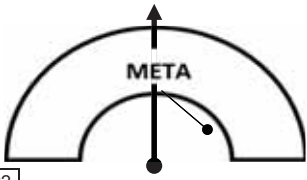
DISTANCIA		DIRECCIÓN DIRECTION	TIERRA	INFORMACIÓN INFORMATION	DIST. REG. TO GO
TOTAL	PARCIAL				
23.460	0.250			SEMÁFORO DE FRENTE	1.670
		21			
23.520	0.060			META FIN DEL RALLY WALMART TEHUACÁN "FELICIDADES"	0.110
		22			

DISTANCIA A LA PRÓXIMA INSTRUCCIÓN