

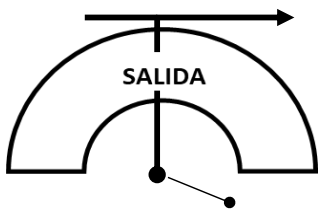

TC CH	0	SALIDA ZÓCALO DE TEHUACÁN.	DISTANCIA	0
	1	ACATEPEC	35.880 Km.	
			PROMEDIO-AVERAGE	TIEMPO TIME 00:45
			47.8 KM/H	

DISTANCIA		DIRECCIÓN DIRECTION	TIERRA	INFORMACIÓN INFORMATION	DIST. REG.
TOTAL	PARCIAL				TO GO
0.000	0.000			 CONTROL "CH" SALIDA EXPLANADA ZÓCALO A LA DERECHA POR CALLE 1 ORIENTE	35.880
0.120	0.120			A LA DERECHA POR CALLE 1 SUR.	35.760
0.200	0.080			SEMAFORO, DE FRENTE POR CALLE 1 NORTE. (AV. INDEPENDENCIA)	35.680
0.550	0.350			A LA IZQUIERDA POR CALLE 2 ORIENTE	35.330
0.650	0.100			SEMÁFORO A LA IZQUIERDA POR AV. REFORMA NTE.	35.230

DISTANCIA A LA PRÓXIMA INSTRUCCIÓN	0.230
------------------------------------	-------

TC CH TC CH	0	SALIDA ZÓCALO DE TEHUACÁN.	DISTANCIA	0
	1	ACATEPEC	35.880 Km.	
			PROMEDIO-AVERAGE	TIEMPO TIME 00:45
			47.8 KM/H	

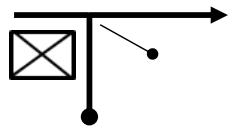
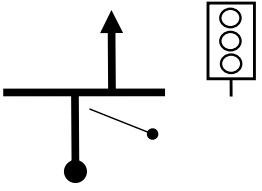
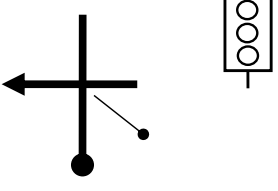
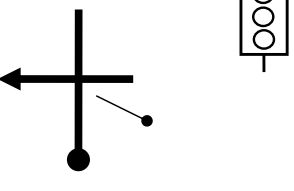
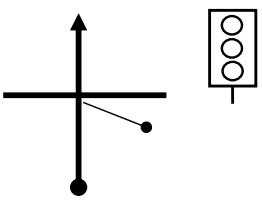
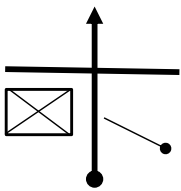
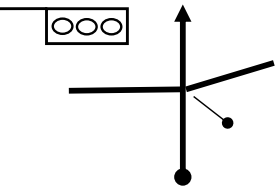
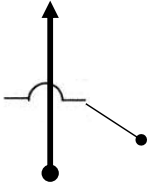
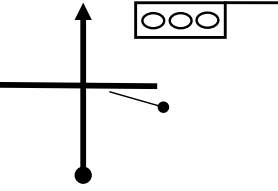
DISTANCIA		DIRECCIÓN DIRECTION	TIERRA	INFORMACIÓN INFORMATION	DIST. REG. TO GO
TOTAL	PARCIAL				
0.880	0.230			SEMÁFOROS (5) SEGUIR DE FRENTE	35.000
		6			
1.750	0.870			PEMEX LADO IZQ. DE FRENTE	34.130
		7			
1.870	0.120			SEMÁFORO DE FRENTE	34.010
		8			
2.520	0.650			TOPES (2)	33.360
		9			
2.840	0.320			SEMÁFORO DE FRENTE	33.040
		10			

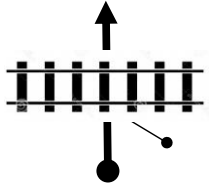
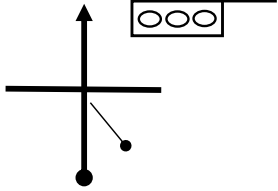
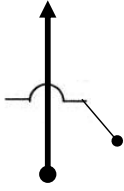
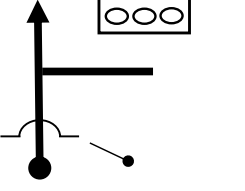
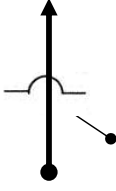

DISTANCIA A LA PRÓXIMA INSTRUCCIÓN	0.420
------------------------------------	-------

TC CH TC CH	0	SALIDA ZÓCALO DE TEHUACÁN.	DISTANCIA	0
	1	ACATEPEC	35.880 Km.	
			PROMEDIO-AVERAGE	TIEMPO TIME 00:45
			47.8 KM/H	

DISTANCIA		DIRECCIÓN DIRECTION	TIERRA	INFORMACIÓN INFORMATION	DIST. REG. TO GO
TOTAL	PARCIAL				
3.260	0.420			CRUCE F.F.C.C.	32.620
		11			
3.430	0.170			SEMÁFORO DE FRENTE	32.450
		12			
3.840	0.410			TOPE	32.040
		13			
4.190	0.350			TOPE SEMÁFORO DE FRENTE	31.690
		14			
4.660	0.470			TOPE	31.220
		15			

DISTANCIA A LA PRÓXIMA INSTRUCCIÓN	0.180
------------------------------------	-------

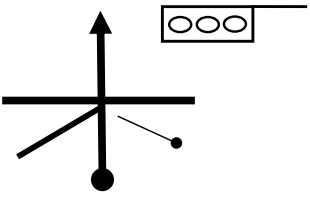
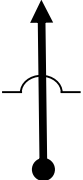
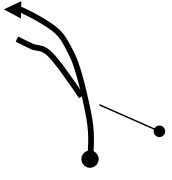
TC CH	0	SALIDA ZÓCALO DE TEHUACÁN.	DISTANCIA	0
	1	ACATEPEC	35.880 Km.	
			PROMEDIO-AVERAGE	TIEMPO TIME 00:45
			47.8 KM/H	

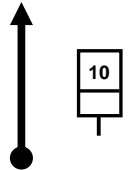
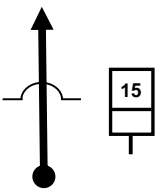
DISTANCIA		DIRECCIÓN DIRECTION	TIERRA	INFORMACIÓN INFORMATION	DIST. REG. TO GO
TOTAL	PARCIAL				
4.840	0.180			SEMÁFORO DE FRENTE	31.040
		16			
5.060	0.220			TOPE	30.820
		17			
5.610	0.550			 POR LA DERECHA A HUAJUAPAN	30.270
		18			
7.030	1.420			KM. 10	28.850
		19			
11.980	4.950			KM. 15 TOPES (4)	23.900
		20			





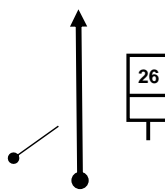
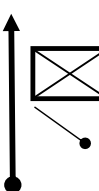
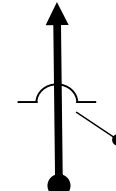
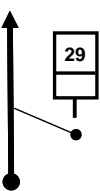
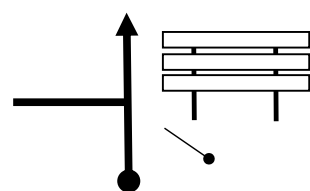

DISTANCIA A LA PRÓXIMA INSTRUCCIÓN	10.950
------------------------------------	--------

TC CH	0	SALIDA ZÓCALO DE TEHUACÁN.	DISTANCIA	0
	1	ACATEPEC	35.880 Km.	
			PROMEDIO-AVERAGE	TIEMPO TIME 00:45
			47.8 KM/H	

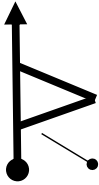
DISTANCIA		DIRECCIÓN DIRECTION	TIERRA	INFORMACIÓN INFORMATION	DIST. REG. TO GO
TOTAL	PARCIAL				
22.930	10.950			KM. 26	12.950
		21			
23.540	0.610			PEMEX LADO DERECHO SE PERMITE RECARGA.	12.340
		22			
23.880	0.340			TOPES (4) ZAPOTITLÁN SALINAS	12.000
		23			
25.910	2.030			KM. 29	9.970
		24			
29.470	3.560			LETRERO TRIPLE METZONTLA, ATOLOITLAN, COATEPEC DE FRENTE	6.410
		25			

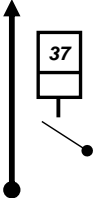
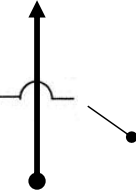
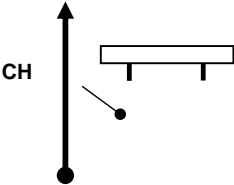
DISTANCIA A LA PRÓXIMA INSTRUCCIÓN	0.870
------------------------------------	-------

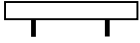

TC CH TC CH	0	SALIDA ZÓCALO DE TEHUACÁN.	DISTANCIA	0
	1	ACATEPEC	35.880 Km.	
			PROMEDIO-AVERAGE	TIEMPO TIME 00:45
			47.8 KM/H	

DISTANCIA		DIRECCIÓN DIRECTION	TIERRA	INFORMACIÓN INFORMATION	DIST. REG. TO GO
TOTAL	PARCIAL				
30.340	0.870	 26		 LETRERO TELOXTOC DE FRENTE	5.540
33.920	3.580	 27		KM. 37	0.960
34.210	0.290	 28		TOPES (3)	1.670
35.770	1.560	 29		 CONTROL "C" LETRERO "NO REBASE"	0.110
35.880	0.110	  30		 CONTROL "A" SEÑAL INVERTIDA L.I.	0.000

DISTANCIA A LA PRÓXIMA INSTRUCCIÓN

1° RALLY RETO NOCTURNO. jmgf-18

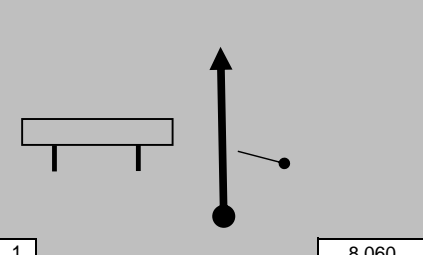
TC CH	1	ACATEPEC	DISTANCIA	1
	2	CHAZUMBA	14.360 Km.	
1	ACATEPEC		8.060 Km.	PROMEDIO-AVERAGE
			61.5 Km/h	TIEMPO TIME 00:14

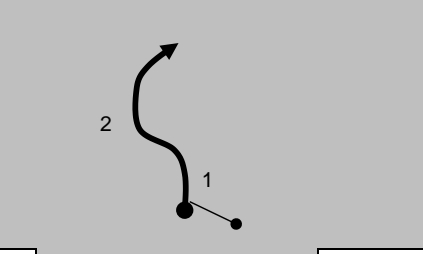
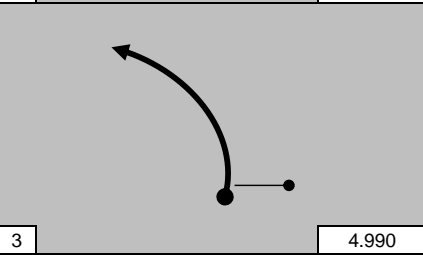
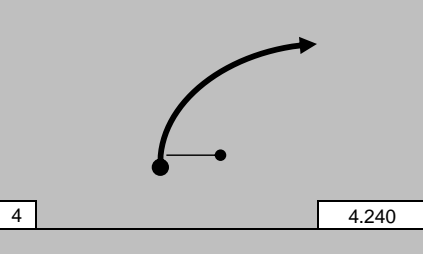
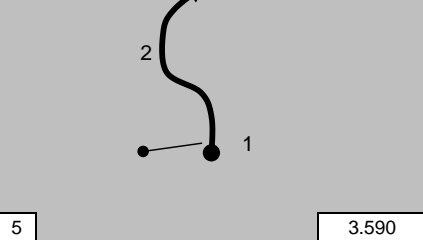
DISTANCIA		DIRECCIÓN DIRECTION	TIERRA	INFORMACIÓN INFORMATION	DIST. REG. TO GO
TOTAL	PARCIAL				
0.000	0.000			 <p>CONTROL "A" LETRERO INVERTIDO N18°16.020' W97°32.536'</p>	14.360
1.630	1.630			<p>1 ! 2 !</p>	12.730
3.070	1.440			<p>!! LARGA</p>	11.290
3.820	0.750			<p>!!</p>	10.540
4.470	0.650			<p>1 !! 2 !!</p>	9.890







DISTANCIA A LA PRÓXIMA INSTRUCCIÓN 1.330

TC CH	1	ACATEPEC	DISTANCIA	1	
	2	CHAZUMBA	14.360 Km.		
1	ACATEPEC		8.060 Km.	PROMEDIO-AVERAGE	
				61.5 Km/h	TIEMPO TIME 00:14

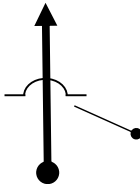
DISTANCIA		DIRECCIÓN DIRECTION	TIERRA	INFORMACIÓN INFORMATION	DIST. REG. TO GO
TOTAL	PARCIAL				
5.800	1.330			!	8.560
6.230	0.430			!	8.130
6.500	0.270			!!	7.860
7.390	0.890			1 !! 2 !!	6.970
8.060	0.670			CONTROL "B" KM. 47 N18°14.101' W97°34.677'	6.300

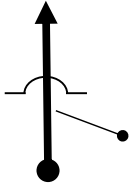
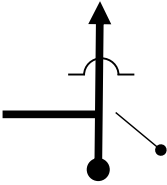

DISTANCIA A LA PRÓXIMA INSTRUCCIÓN	0.410
------------------------------------	-------

TC CH TC CH	1	ACATEPEC	DISTANCIA	1
	2	CHAZUMBA	14.360 Km.	
1	ACATEPEC		8.060 Km.	PROMEDIO-AVERAGE
				61.5 Km/h
				TIEMPO TIME
				00:14

DISTANCIA		DIRECCIÓN DIRECTION	TIERRA	INFORMACIÓN INFORMATION	DIST. REG. TO GO
TOTAL	PARCIAL				
8.470	0.410			 CONTROL "C" EN TOPE	5.890
		11			
8.770	0.300			TOPE	5.590
		12			
8.870	0.100			DE FRENTE EN ENTRONQUE TOPE	5.490
		13			
11.970	3.100			KM. 51	2.390
		14			
14.160	2.190			 CONTROL "CH" INICIO DE RIEL LADO DERECHO.	0.200
		15			

DISTANCIA A LA PRÓXIMA INSTRUCCIÓN	0.200
------------------------------------	-------

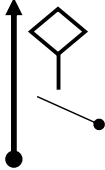



TC CH TC CH	1	ACATEPEC	DISTANCIA	1
	2	CHAZUMBA	14.360 Km.	
1	ACATEPEC	8.060 Km.	PROMEDIO-AVERAGE	TIEMPO TIME
			61.5 Km/h	00:14

DISTANCIA		DIRECCIÓN DIRECTION	TIERRA	INFORMACIÓN INFORMATION	DIST. REG. TO GO
TOTAL	PARCIAL				
14.360	0.200			 CONTROL "A" SEÑAL CURVA	0.000
		16			
		17			
		18			
		19			
		20			

DISTANCIA A LA PRÓXIMA INSTRUCCIÓN

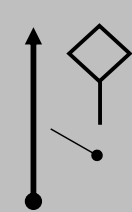

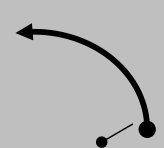
1° RALLY RETO NOCTURNO. jmgf-18

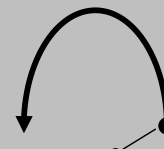
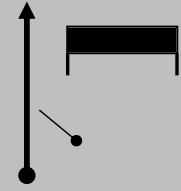
SS TC TC CH	2	CHAZUMBA	DISTANCIA	2	
	3	ATZUMBA	14.490 Km.		
2	CHAZUMBA		7.630 Km.	PROMEDIO-AVERAGE	
				39.5 Km/h	TIEMPO TIME 00:22

DISTANCIA		DIRECCIÓN DIRECTION	TIERRA	INFORMACIÓN INFORMATION	DIST. REG. TO GO
TOTAL	PARCIAL				
0.000	0.000			 CONTROL "A" SEÑAL CURVA N18°12' 50.84" W97°37' 37.80"	14.490
		1 7.630			
0.430	0.430				14.060
		2 7.200			
1.450	1.020			!!!	13.040
		3 6.180			
2.090	0.640			!!!	12.400
		4 5.540			
2.460	0.370			PRIMER LETRERO BIENVENIDOS A OAXACA	12.030
		5 5.170			

DISTANCIA A LA PRÓXIMA INSTRUCCIÓN	0.380
------------------------------------	-------

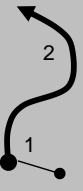
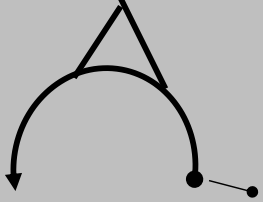
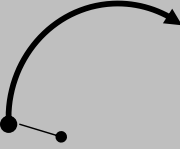
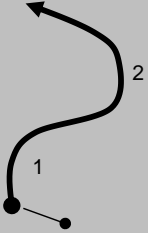
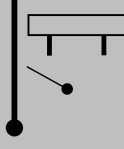
SS TC TC CH	2	CHAZUMBA	DISTANCIA	2	
	3	ATZUMBA	14.490 Km.		
2	CHAZUMBA		7.630 Km.	PROMEDIO-AVERAGE	
				39.5 Km/h	TIEMPO TIME 00:22



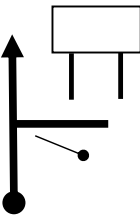
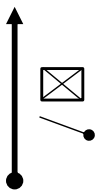
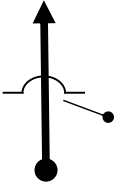
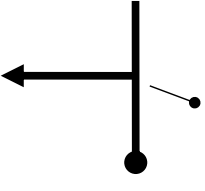
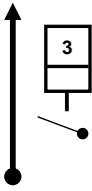

DISTANCIA		DIRECCIÓN DIRECTION	TIERRA	INFORMACIÓN INFORMATION	DIST. REG. TO GO
TOTAL	PARCIAL				
2.840	0.380			1 ! 2 !	11.650
		6 4.790			
3.880	1.040			!!	10.610
		7 3.750			
5.430	1.550			!!	9.060
		8 2.200			
6.070	0.640			1 !! 2 !!	8.420
		9 1.560			
7.630	1.560			 CONTROL "B" LETRERO NO DEJE PIEDRAS... N18°12' 03.87" W97°40'20.09"	6.860
		10 0.000			

DISTANCIA A LA PRÓXIMA INSTRUCCIÓN	0.580
------------------------------------	-------

SS TC TC CH	2	CHAZUMBA	DISTANCIA	2	
	3	ATZUMBA	14.490 Km.		
2	CHAZUMBA		7.630 Km.	PROMEDIO-AVERAGE	
				39.5 Km/h	TIEMPO TIME 00:22

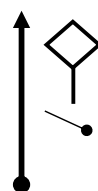
DISTANCIA		DIRECCIÓN	TIERRA	INFORMACIÓN INFORMATION	DIST. REG. TO GO
TOTAL	PARCIAL				
8.210	0.580			STOP CONTROL "C" LETRERO CONTRUYE... Y ENTRONQUE.	6.280
		11			
8.930	0.720			PEMEX LADO DERECHO SE PERMITE RECARGA	5.560
		12			
9.110	0.180			TOPES (3)	5.380
		13			
10.050	0.940			A LA IZQUIERDA A TRUJAPAN (PRECAUCIÓN)	4.440
		14			
13.030	2.980			KM. 3	1.460
		15			
DISTANCIA A LA PRÓXIMA INSTRUCCIÓN		1.290			

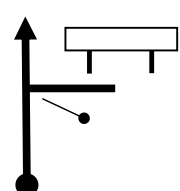
SS TC TC CH	2	CHAZUMBA	DISTANCIA		2
	3	ATZUMBA	14.490 Km.		
2	CHAZUMBA		7.630 Km.	PROMEDIO-AVERAGE	TIEMPO TIME 00:22
				39.5 Km/h	

DISTANCIA		DIRECCIÓN DIRECTION	TIERRA	INFORMACIÓN INFORMATION	DIST. REG. TO GO
TOTAL	PARCIAL				
14.320	1.290			 CONTROL "CH" SEÑAL LADO DERECHO	0.170
		16			
14.490	0.170			 CONTROL "A" LETRERO SAN J. TRUJAPAN.	0.000
		17			

SS TC TC CH	3	ATZUMBA	DISTANCIA		3
	4	CALTEPEC	18.040 Km.		
4	ATZUMBA		17.280 Km	18	TIEMPO TIME
				60.1 Km/h	00:18

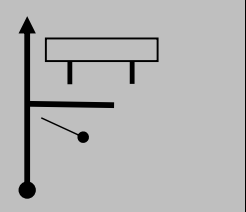
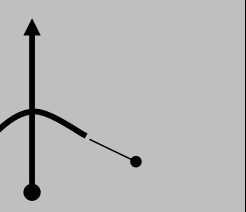
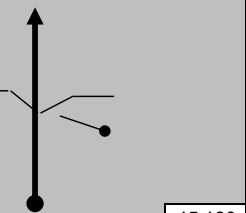
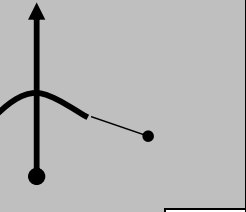
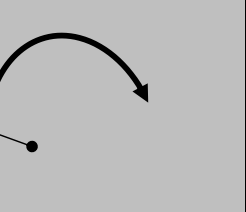
DISTANCIA		DIRECCIÓN DIRECCION	TIERRA	INFORMACIÓN INFORMATION	DIST. REG. TO GO
TOTAL	PARCIAL				
0.000	0.000			CONTROL "A" LETRERO SAN J. TRUJAPAN. N 18° 10.216' W 97° 38.700'	18.040
		1	17.280		
1.540	1.540			LOMO	16.500
		2	15.740		
2.100	0.560			!!	15.940
		3	15.180		
2.900	0.800			LOMO	15.140
		4	14.380		
3.180	0.280			!!	14.860
		5	14.100		

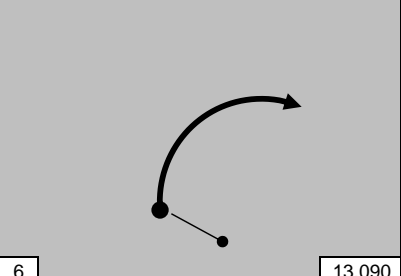
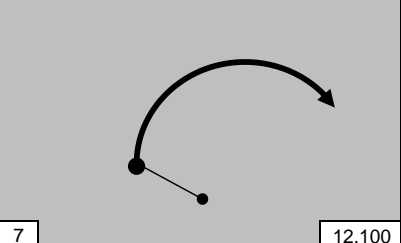
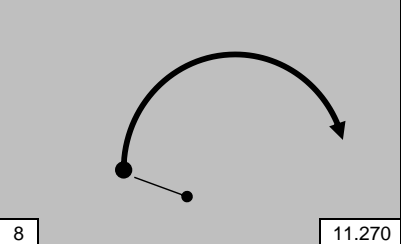
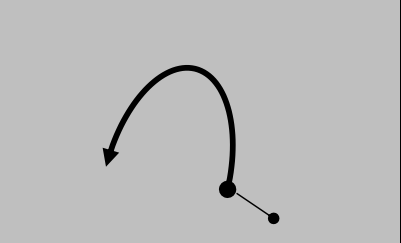
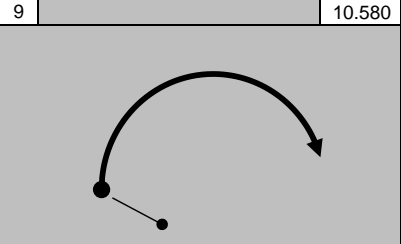

DISTANCIA A LA PRÓXIMA INSTRUCCIÓN	1.010
------------------------------------	-------

SS TC TC CH	3	ATZUMBA	DISTANCIA	3
	4	CALTEPEC	18.040 Km.	
4	ATZUMBA	17.280 Km	18	TIEMPO TIME 00:18
			60.1 Km/h	

DISTANCIA		DIRECCIÓN DIRECCION	TIERRA	INFORMACIÓN INFORMATION	DIST. REG. TO GO
TOTAL	PARCIAL				
4.190	1.010			!	13.850
5.180	0.990			!!	12.860
6.010	0.830			!!	12.030
6.700	0.690			!!!	11.340
7.220	0.520			!!	10.820

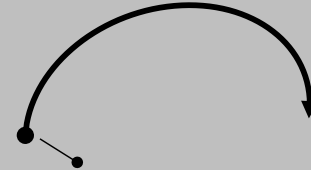
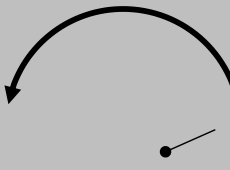

DISTANCIA A LA PRÓXIMA INSTRUCCIÓN 1.180

SS TC TC CH	3	ATZUMBA	DISTANCIA	3
	4	CALTEPEC	18.040 Km.	
4	ATZUMBA		17.280 Km	18
				TIEMPO TIME 00:18
				60.1 Km/h

DISTANCIA		DIRECCIÓN DIRECTION	TIERRA	INFORMACIÓN INFORMATION	DIST. REG. TO GO
TOTAL	PARCIAL				
8.400	1.180	 11 8.880		!!	9.640
9.170	0.770	 12 8.110		PUENTE Y !!	8.870
9.350	0.180	 13 7.930		!!!	8.690
10.400	1.050	 14 6.880		! LARGA	7.640
10.700	0.300	 15 6.580		LARGA	7.340



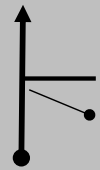
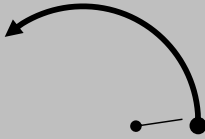
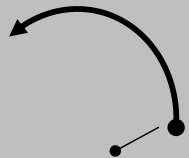
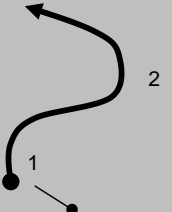
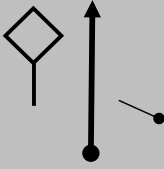



DISTANCIA A LA PRÓXIMA INSTRUCCIÓN 3.030

SS TC TC CH	3	ATZUMBA	DISTANCIA		3
	4	CALTEPEC	18.040 Km.		
4	ATZUMBA		17.280 Km	18	TIEMPO TIME
				60.1 Km/h	00:18

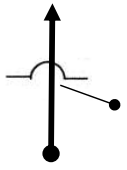
DISTANCIA		DIRECCIÓN DIRECCION	TIERRA	INFORMACIÓN INFORMATION	DIST. REG. TO GO
TOTAL	PARCIAL				
13.730	3.030			DE FRENTE	4.310
		16 3.550			
15.280	1.550			!	2.760
		17 2.000			
16.670	1.390			!	1.370
		18 0.610			
17.070	0.400			1 ! 2 !!	0.970
		19 0.210			
17.280	0.210			 CONTROL "B" SEÑAL INVERTIDA LADO IZQUIERDO N18°12.055' W97°33.390'	0.760
		20 0.000			

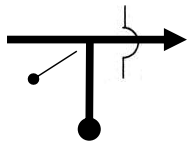
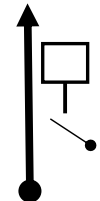

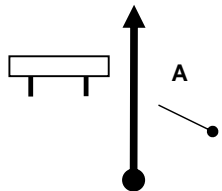
DISTANCIA A LA PRÓXIMA INSTRUCCIÓN	0.300
------------------------------------	-------

SS TC TC CH	3	ATZUMBA	DISTANCIA		3	
	4	CALTEPEC	18.040 Km.			
4	ATZUMBA		17.280 Km	18	TIEMPO TIME	00:18
			60.1 Km/h			

DISTANCIA		DIRECCIÓN DIRECCION	TIERRA	INFORMACIÓN INFORMATION	DIST. REG. TO GO
TOTAL	PARCIAL				
17.580	0.300			 CONTROL "C" TOPES (2)	0.460
		21			
17.840	0.260			A LA DERECHA Y TOPE.	0.200
		22			
17.950	0.110			 CONTROL "CH" SEÑAL 40 Km/h	0.090
		23			
18.040	0.090			 CONTROL "A" LETRERO INVERTIDO LADO IZQUIERDO	0.000
		24			
		25			

DISTANCIA A LA PRÓXIMA INSTRUCCIÓN

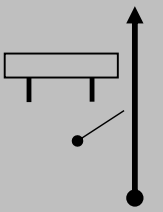
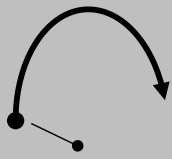
SS TC TC CH	4	CALTEPEC	DISTANCIA	4
	5	ATECOXCO	13.260 Km.	
4	CALTEPEC		11.820 Km.	PROMEDIO-AVERAGE
			62.8 Km/h	TIEMPO TIME 00:12 + 01:00

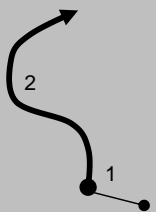
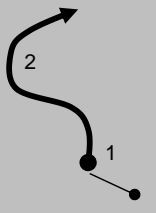
DISTANCIA		DIRECCIÓN DIRECCION	TIERRA	INFORMACIÓN INFORMATION	DIST. REG. TO GO
TOTAL	PARCIAL				
0.000	0.000			CONTROL "A" LETRERO INVERTIDO N18°12.231' W97°33.139'	13.260
		1	11.820		
0.880	0.880			!!!	12.380
		2	10.940		
2.300	1.420			!!	10.960
		3	9.520		
2.490	0.190			1 !! 2 !	10.770
		4	9.330		
2.720	0.230			1 ! 2 !!	10.540
		5	9.100		

DISTANCIA A LA PRÓXIMA INSTRUCCIÓN	1.010
------------------------------------	-------

SS TC TC CH	4	CALTEPEC	DISTANCIA	4
	5	ATECOXCO	13.260 Km.	
4	CALTEPEC		11.820 Km.	PROMEDIO-AVERAGE
				62.8 Km/h
				TIEMPO TIME 00:12 + 01:00

DISTANCIA		DIRECCIÓN DIRECTION	TIERRA	INFORMACIÓN INFORMATION	DIST. REG. TO GO
TOTAL	PARCIAL				
3.730	1.010			!!!	9.530
		6 8.090			
3.930	0.200			!!!	9.330
		7 7.890			
4.470	0.540			!!	8.790
		8 7.350			
4.580	0.110			1 !! 2 !!!	8.680
		9 7.240			
5.320	0.740			1 ! 2 !!	7.940
		10 6.500			



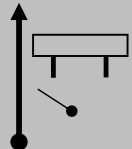
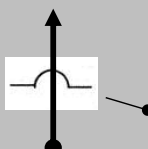
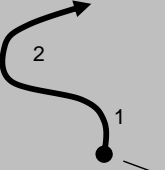
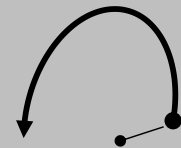

DISTANCIA A LA PRÓXIMA INSTRUCCIÓN 0.860

SS TC TC CH	4	CALTEPEC	DISTANCIA	4
	5	ATECOXCO	13.260 Km.	
4	CALTEPEC		11.820 Km.	PROMEDIO-AVERAGE
				62.8 Km/h
				TIEMPO TIME 00:12 + 01:00

DISTANCIA		DIRECCIÓN DIRECCION	TIERRA	INFORMACIÓN INFORMATION	DIST. REG. TO GO
TOTAL	PARCIAL				
6.180	0.860	 11 5.640		!!!	7.080
6.610	0.430	 12 5.210		LA COMPAÑÍA	6.650
6.970	0.360	 13 4.850		TOPES (2)	6.290
9.280	2.310	 14 2.540		1 ! 2 !!!	3.980
9.980	0.700	 15 1.840		!! LARGA	3.280

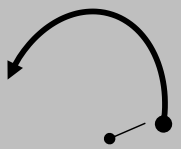
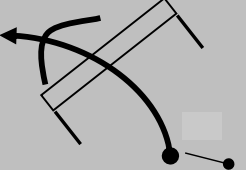
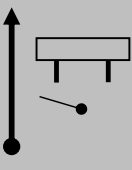
DISTANCIA A LA PRÓXIMA INSTRUCCIÓN	0.420
------------------------------------	-------

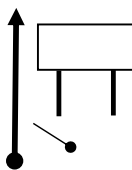
SS TC TC CH	4	CALTEPEC	DISTANCIA		4
	5	ATECOXCO	13.260 Km.		
4	CALTEPEC		11.820 Km.	PROMEDIO-AVERAGE	TIEMPO TIME
				62.8 Km/h	

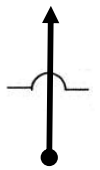
DISTANCIA		DIRECCIÓN DIRECCION	TIERRA	INFORMACIÓN INFORMATION	DIST. REG. TO GO
TOTAL	PARCIAL				
10.400	0.420	 16 1.420		!!	2.860
11.110	0.710	 17 0.710			2.150
11.820	0.710	 18 0.000		 CONTROL "B" LETRERO POBLADO PRÓXIMO N18°11.274' W97°28.955'	1.440
12.110	0.290	 19		 CONTROL "C" LETRERO CALTEPEC INICIA ADOQUÍN	1.150
12.210	0.100	 20		TOPES (2)	1.050





DISTANCIA A LA PRÓXIMA INSTRUCCIÓN	0.170
------------------------------------	-------

SS TC TC CH	4	CALTEPEC	DISTANCIA		4
	5	ATECOXCO	13.260 Km.		
4	CALTEPEC		11.820 Km.	PROMEDIO-AVERAGE	TIEMPO TIME
				62.8 Km/h	

DISTANCIA		DIRECCIÓN DIRECCION	TIERRA	INFORMACIÓN INFORMATION	DIST. REG. TO GO
TOTAL	PARCIAL				
12.380	0.170			INICIA CAMELLÓN	0.880
		21			
12.490	0.110			TOPE	0.770
		22			
12.570	0.080			A LA IZQUIERDA EN "U", DONDE TERMINA CAMELLÓN	0.690
		23		CONTROL "CH"	
12.650	0.080			TOPE	0.610
		24			
12.860	0.210			CASETA AZUL LADO DERECHO TOPES (2) FORMARSE A PARTIR DE ESTE PUNTO.	0.400
		25			

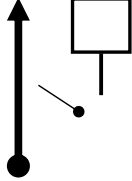
DISTANCIA A LA PRÓXIMA INSTRUCCIÓN	0.290
------------------------------------	-------

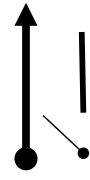
SS TC TC CH	4	CALTEPEC	DISTANCIA		4
	5	ATECOXCO	13.260 Km.		
4	CALTEPEC		11.820 Km.	PROMEDIO-AVERAGE	TIEMPO TIME
				62.8 Km/h	

DISTANCIA		DIRECCIÓN DIRECTION	TIERRA	INFORMACIÓN INFORMATION	DIST. REG. TO GO
TOTAL	PARCIAL				
13.150	0.290			 CONTROL "CH" SEÑAL 40 Km/h	0.110
		26			
13.260	0.110			 CONTROL "A" POSTE SIN SEÑAL.	0.000
		27			

DISTANCIA A LA PRÓXIMA INSTRUCCIÓN

SS TC TC CH	5	ATECOXCO	DISTANCIA	5
	6	TRUJAPAN	16.420 Km.	
5	ATECOXCO		11.450 Km	PROMEDIO-AVERAGE
			61.6 Km/h	TIEMPO TIME 00:16

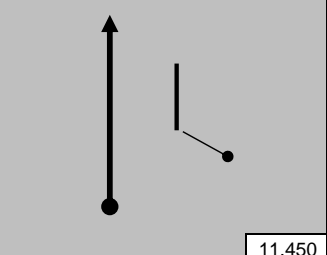
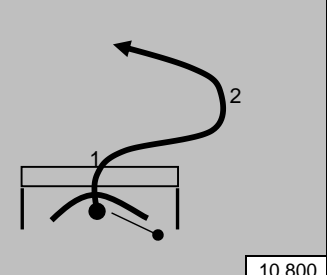
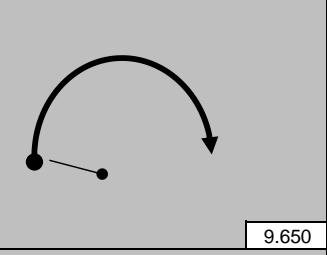
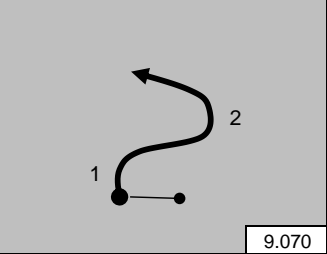
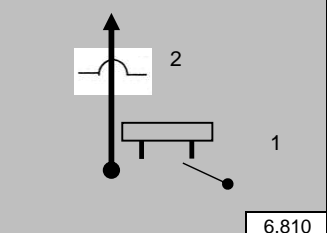
DISTANCIA		DIRECCIÓN DIRECCION	TIERRA	INFORMACIÓN INFORMATION	DIST. REG. TO GO
TOTAL	PARCIAL				
0.000	0.000			CONTROL "A" POSTE SIN SEÑAL L.D. N18°11.243' W97°28.929'	16.420
0.650	0.650			LOMO 1 ! 2 !!!	15.770
1.800	1.150			!!	14.620
2.380	0.580			1 ! 2 !!!	14.040
4.640	2.260			1 LA COMPAÑÍA 2 TOPES (2)	11.780

DISTANCIA A LA PRÓXIMA INSTRUCCIÓN	0.700
------------------------------------	-------

SS TC TC CH	5	ATECOXCO	DISTANCIA	5	
	6	TRUJAPAN	16.420 Km.		
5	ATECOXCO		11.450 Km	PROMEDIO-AVERAGE	
				61.6 Km/h	TIEMPO TIME 00:16

DISTANCIA		DIRECCIÓN DIRECTION	TIERRA	INFORMACIÓN INFORMATION	DIST. REG. TO GO
TOTAL	PARCIAL				
5.340	0.700			!	11.080
5.420	0.080			1 ! 2 !!!	11.000
6.320	0.900			1 !! 2 !	10.100
6.860	0.540			!	9.560
7.050	0.190			1 !! 2 !	9.370



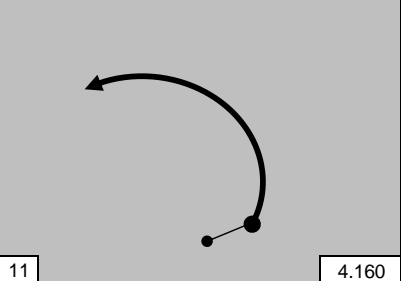
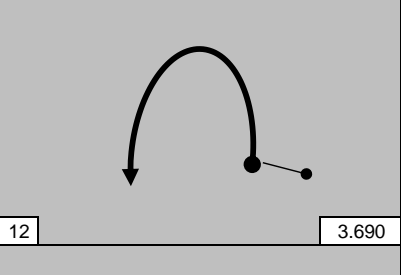
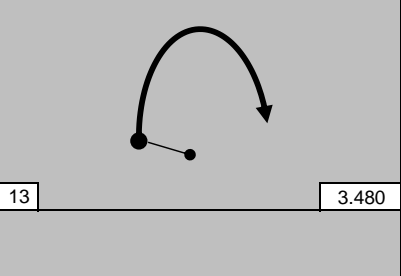
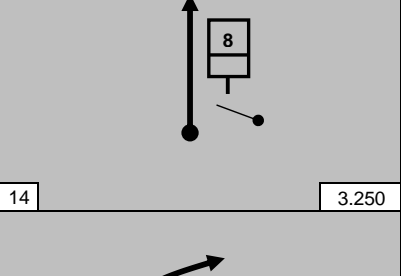
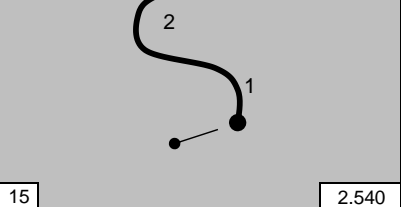

DISTANCIA A LA PRÓXIMA INSTRUCCIÓN	0.240
------------------------------------	-------

SS TC TC CH	5	ATECOXCO	DISTANCIA	5	
	6	TRUJAPAN	16.420 Km.		
5	ATECOXCO		11.450 Km	PROMEDIO-AVERAGE	
				61.6 Km/h	TIEMPO TIME 00:16

DISTANCIA		DIRECCIÓN DIRECCION	TIERRA	INFORMACIÓN INFORMATION	DIST. REG. TO GO
TOTAL	PARCIAL				
7.290	0.240			!	9.130
7.760	0.470			!!!	8.660
7.970	0.210			!!!	8.450
8.200	0.230			KM. 8	8.220
8.910	0.710			1 !! 2 !	7.510

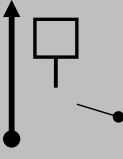

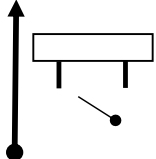

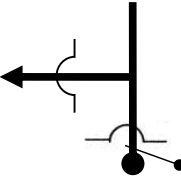
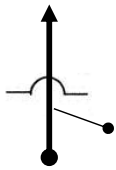
DISTANCIA A LA PRÓXIMA INSTRUCCIÓN	1.930
------------------------------------	-------

SS TC TC CH	5	ATECOXCO	DISTANCIA		5
	6	TRUJAPAN	16.420 Km.		
5	ATECOXCO		11.450 Km	PROMEDIO-AVERAGE	TIEMPO TIME 00:16
				61.6 Km/h	

DISTANCIA		DIRECCIÓN DIRECCION	TIERRA	INFORMACIÓN INFORMATION	DIST. REG. TO GO
TOTAL	PARCIAL				
10.840	1.930	 16 0.610		!!	5.580
11.450	0.610	 17 0.000		 CONTROL "B" SEÑAL 40 KM/H N18°12.055' W97°32.949'	4.970
11.820	0.370	 18		 CONTROL "C" LETRERO POBLADO PRÓXIMO.	4.600
12.010	0.190	 19		TOPE A LA IZQUIERDA A TRUJAPAN TOPE	4.410
12.290	0.280	 20		TOPE	4.130

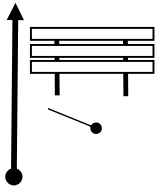

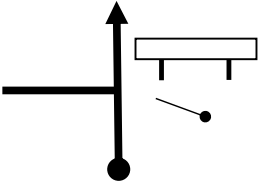



DISTANCIA A LA PRÓXIMA INSTRUCCIÓN	4.060
------------------------------------	-------

SS TC TC CH	5	ATECOXCO	DISTANCIA		5
	6	TRUJAPAN	16.420 Km.		
5	ATECOXCO		11.450 Km	PROMEDIO-AVERAGE	TIEMPO TIME
				61.6 Km/h	00:16

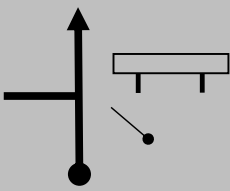
DISTANCIA		DIRECCIÓN DIRECTION	TIERRA	INFORMACIÓN INFORMATION	DIST. REG. TO GO
TOTAL	PARCIAL				
16.350	4.060			 CONTROL "CH" LETRERO TRIPLE	0.070
		21			
16.420	0.070			 CONTROL "A" LETRERO "SAN PABLO"	0.000
		22			
		23			
		24			
		25			

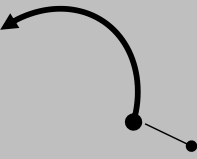

DISTANCIA A LA PRÓXIMA INSTRUCCIÓN

SS TC TC CH	6	TRUJAPAN	DISTANCIA	6
	6A	SERVICIO GASOLINERA CHAZUMBA	18.890 Km.	
6	TRUJAPAN	13.500 Km.	PROMEDIO-AVERAGE	TIEMPO TIME
			63Km/h	00:18

DISTANCIA		DIRECCIÓN DIRECTION	TIERRA	INFORMACIÓN INFORMATION	DIST. REG. TO GO
TOTAL	PARCIAL				
0.000	0.000			 CONTROL "A" LETRERO SAN PABLO. N 18°10' 26.77" W 97° 34' 23.28"	18.890
		1 13.500			
0.610	0.610			!!	18.280
		2 12.890			
2.170	1.560			!!	16.720
		3 11.330			
2.610	0.440			!!!	16.280
		4 10.890			
3.360	0.750			!!!	15.530
		5 10.140			

DISTANCIA A LA PRÓXIMA INSTRUCCIÓN	0.370
------------------------------------	-------

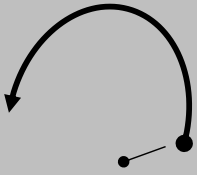
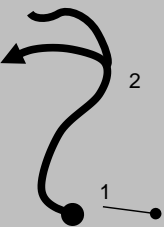
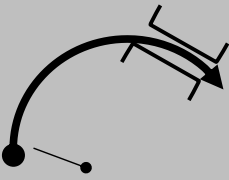
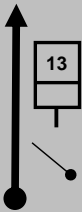
SS TC TC CH	6	TRUJAPAN	DISTANCIA	6
	6A	SERVICIO GASOLINERA CHAZUMBA	18.890 Km.	
6	TRUJAPAN	13.500 Km.	PROMEDIO-AVERAGE	TIEMPO TIME
			63Km/h	00:18

DISTANCIA		DIRECCIÓN DIRECTION	TIERRA	INFORMACIÓN INFORMATION	DIST. REG. TO GO
TOTAL	PARCIAL				
3.730	0.370	 6 9.770		!!!	15.160
3.920	0.190	 7 9.580		1 !!, 2 !!!	14.970
4.230	0.310	 8 9.270		!! Y PUENTE	14.660
4.900	0.670	 9 8.600		Km. 13	13.990
5.040	0.140	 10 8.460		!!	13.850



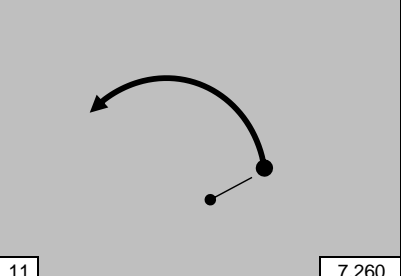
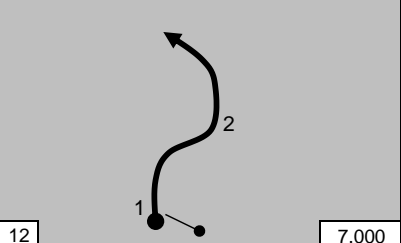
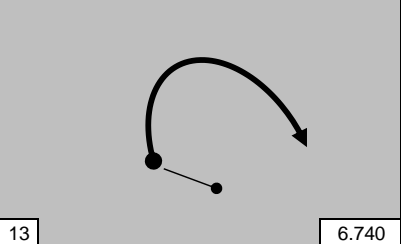
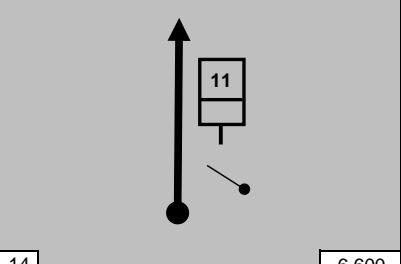
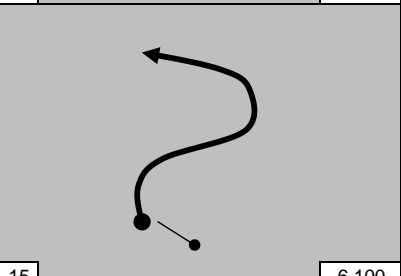

DISTANCIA A LA PRÓXIMA INSTRUCCIÓN 1.200

SS TC TC CH	6	TRUJAPAN	DISTANCIA	6
	6A	SERVICIO GASOLINERA CHAZUMBA	18.890 Km.	
6	TRUJAPAN	13.500 Km.	PROMEDIO-AVERAGE	TIEMPO TIME 00:18
			63Km/h	

DISTANCIA		DIRECCIÓN DIRECTION	TIERRA	INFORMACIÓN INFORMATION	DIST. REG. TO GO
TOTAL	PARCIAL				
6.240	1.200			!	12.650
6.500	0.260			1 !!, 2 !!	12.390
6.760	0.260			!!!	12.130
6.900	0.140			Km. 11	11.990
7.400	0.500			!!	11.490



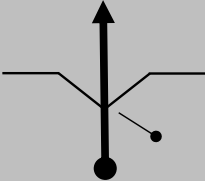

DISTANCIA A LA PRÓXIMA INSTRUCCIÓN	0.770
------------------------------------	-------

SS TC TC CH	6	TRUJAPAN	DISTANCIA	6
	6A	SERVICIO GASOLINERA CHAZUMBA	18.890 Km.	
6	TRUJAPAN	13.500 Km.	PROMEDIO-AVERAGE	TIEMPO TIME
			63Km/h	00:18

DISTANCIA		DIRECCIÓN DIRECTION	TIERRA	INFORMACIÓN INFORMATION	DIST. REG. TO GO
TOTAL	PARCIAL				
8.170	0.770	 16 5.330		!!	10.720
8.910	0.740	 17 4.590		!!	9.980
9.270	0.360	 18 4.230		!!	9.620
10.270	1.000	 19 3.230		!!	8.620
11.380	1.110	 20 2.120		!!	7.510

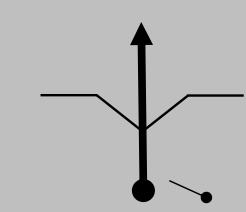
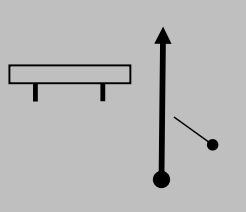

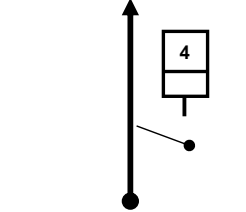
DISTANCIA A LA PRÓXIMA INSTRUCCIÓN	0.400
------------------------------------	-------

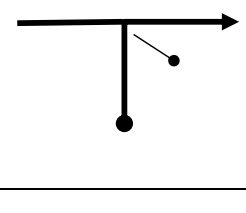
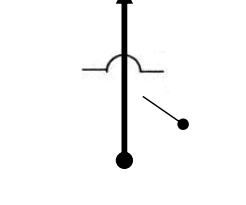
SS TC TC CH	6	TRUJAPAN	DISTANCIA		6
	6A	SERVICIO GASOLINERA CHAZUMBA	18.890 Km.		
6	TRUJAPAN		13.500 Km.	PROMEDIO-AVERAGE	TIEMPO TIME
				63Km/h	

DISTANCIA		DIRECCIÓN DIRECCION	TIERRA	INFORMACIÓN INFORMATION	DIST. REG. TO GO
TOTAL	PARCIAL				
11.780	0.400	 21 1.720		!	7.110
13.500	1.720	 22 0.000		CONTROL "B" LETRERO INV. SAN J. TRUJAPAN N18°12.187' W97°32.949'	5.390
13.940	0.440	 23		CONTROL "C" KM. 4	4.950
17.920	3.980	 24		A LA DERECHA	0.970
18.300	0.380	 25		TOPES (2)	0.590

DISTANCIA A LA PRÓXIMA INSTRUCCIÓN	0.610
------------------------------------	-------

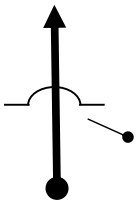
SS TC TC CH	6	TRUJAPAN	DISTANCIA	6
	6A	SERVICIO GASOLINERA CHAZUMBA	18.890 Km.	
6	TRUJAPAN	13.500 Km.	PROMEDIO-AVERAGE	TIEMPO TIME
			63Km/h	00:18

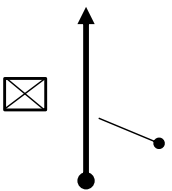
DISTANCIA		DIRECCIÓN DIRECTION	TIERRA	INFORMACIÓN INFORMATION	DIST. REG. TO GO
TOTAL	PARCIAL				
18.860	0.560	 26		 CONTROL "CH" ENTRADA A SERVICIO EN TOPE.	0.030
18.890	0.030	 27		PEMEX LADO IZQUIERDO AREA DE SERVICIO	0.000

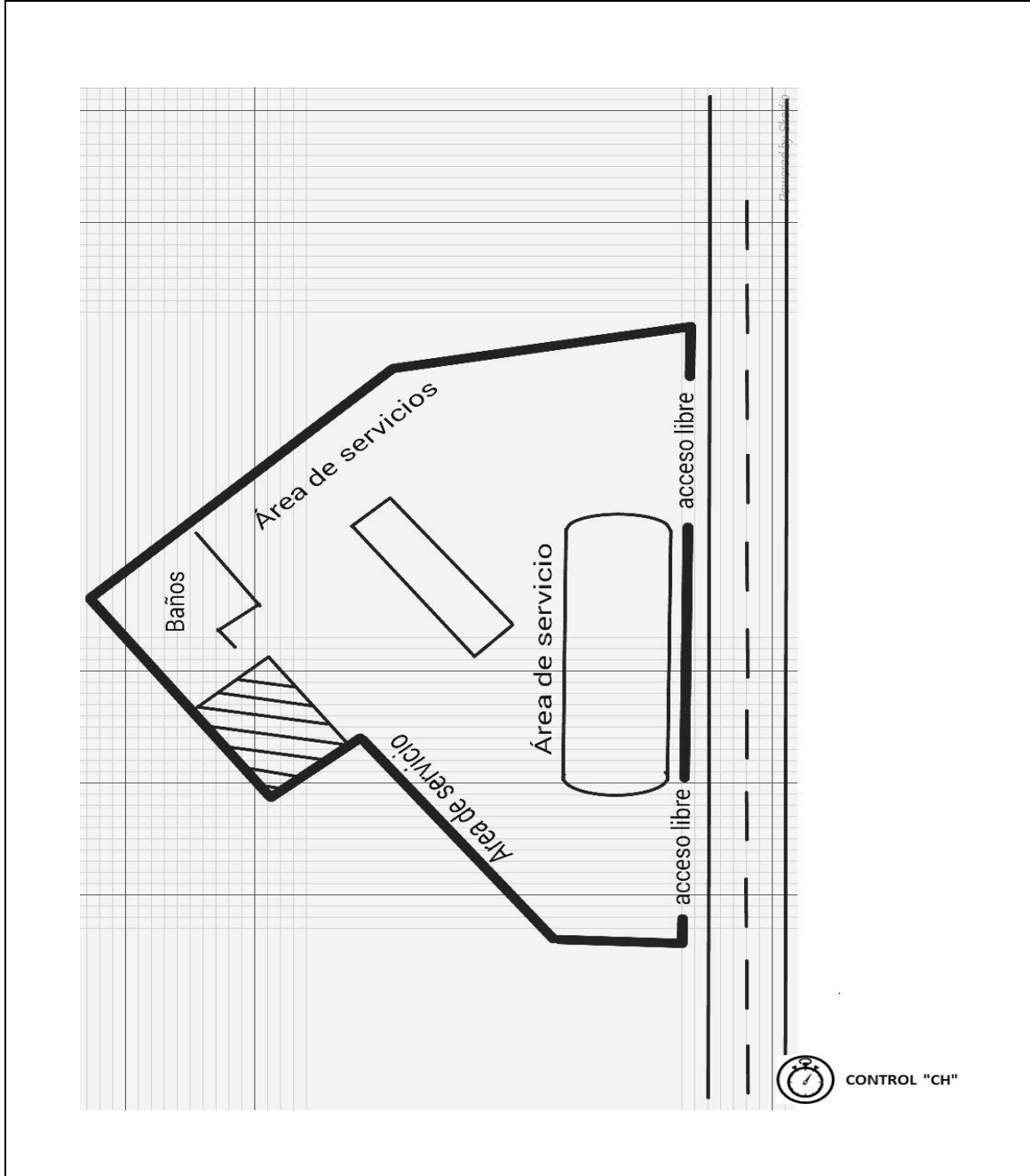

TC CH TC CH	6A	SERVICIO EN GASOLINERA CHAZUMBA	DISTANCIA	6A
	6B	ENTRADA A RECLASIFICACION	0.320 Km.	
			PROMEDIO-AVERAGE	01:00

DISTANCIA		DIRECCIÓN DIRECTION	TIERRA	INFORMACIÓN INFORMATION	DIST. REG. TO GO
TOTAL	PARCIAL				





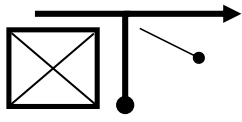
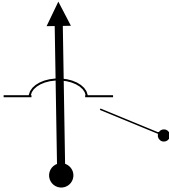
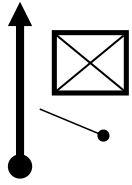

DISTANCIA A LA PRÓXIMA INSTRUCCIÓN

TC CH	6A	SERVICIO EN GASOLINERA CHAZUMBA	DISTANCIA	6A
	6B	ENTRADA A RECLASIFICACION	0.320 Km.	
			PROMEDIO-AVERAGE	01:00

DISTANCIA		DIRECCIÓN DIRECTION	TIERRA	INFORMACIÓN INFORMATION	DIST. REG. TO GO
TOTAL	PARCIAL				
0.000	0.000			SALIDA DE GASOLINERA	0.320
		1			
0.030	0.030			TOPES (2)	0.290
		2			
0.320	0.290			 CONTROL "CH" ENTRADA A RECLASIFICACIÓN GASOLINERA ABANDONADA	0.000
		3			

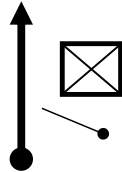
DISTANCIA A LA PRÓXIMA INSTRUCCIÓN

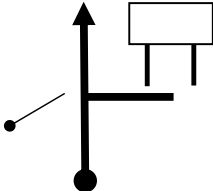
TC CH	6B	ENTRADA A RECLASIFICACION	DISTANCIA	6B
	6C	SALIDA DE RECLASIFICACION	0.110 Km.	
			PROMEDIO-AVERAGE	00:15

DISTANCIA		DIRECCIÓN DIRECTION	TIERRA	INFORMACIÓN INFORMATION	DIST. REG. TO GO
TOTAL	PARCIAL				
0.000	0.000	 1		 CONTROL "CH" ENTRADA A RECLASIFICACIÓN GASOLINERA ABANDONADA	0.110
0.110	0.110	 2		 CONTROL "CH" SALIDA DE RECLASIFICACIÓN LETRERO "SASCH"	0.000



DISTANCIA A LA PRÓXIMA INSTRUCCIÓN 0.000

1° RALLY RETO NOCTURNO

jmgf-2018

www.cnrm.com.mx

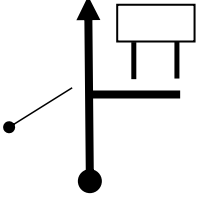
TC CH	6C	SALIDA DE RECLASIFICACION	DISTANCIA	6C
	7	JOLUXTLA	3.780 Km.	
			PROMEDIO-AVERAGE	TIEMPO TIME 00:05
			45.4 Km/h.	

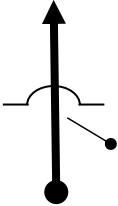
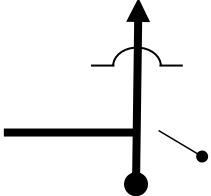
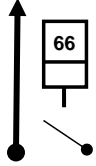
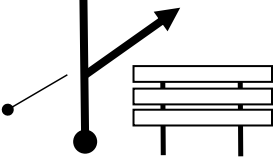
DISTANCIA		DIRECCIÓN DIRECTION	TIERRA	INFORMACIÓN INFORMATION	DIST. REG. TO GO
TOTAL	PARCIAL				
0.000	0.000			 CONTROL "CH" SALIDA DE RECLASIFICACION LETRERO "SASCH"	3.780
0.150	0.150			TOPE	3.630
0.530	0.380			DE FRENTE, TOPE	3.250
1.230	0.700			KM. 66	2.550
1.390	0.160			A LA DERECHA LETRERO TRIPLE.	2.390





51° RALLY MEDIA NOCHE

jmgf-17

www.cnrm.com.mx

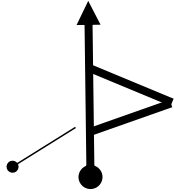
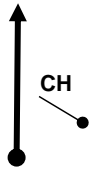
DISTANCIA A LA PRÓXIMA INSTRUCCIÓN	2.230
------------------------------------	-------

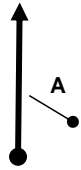
TC CH TC CH	6C	SALIDA DE RECLASIFICACION	DISTANCIA	6C
	7	JOLUXTLA	3.780 Km.	
			PROMEDIO-AVERAGE	TIEMPO TIME 00:05
			45.4 Km/h.	

DISTANCIA		DIRECCIÓN DIRECTION	TIERRA	INFORMACIÓN INFORMATION	DIST. REG. TO GO
TOTAL	PARCIAL				
3.620	2.230			ENTRONQUE DE FRENTE.	0.160
3.730	0.110			 CONTROL "CH" MARCA EN PISO.	0.050
3.780	0.050			 CONTROL "A" MARCA EN PISO Y CUNETETA.	0.000

SS TC TC CH	7	JOLUXTLA	DISTANCIA	7	
	8	LUNATITLÁN	9.630 Km.		
7	JOLUXTLA		8.020 Km.	PROMEDIO-AVERAGE	
				58 Km/h	TIEMPO TIME 00:10

DISTANCIA		DIRECCIÓN DIRECTION	TIERRA	INFORMACIÓN INFORMATION	DIST. REG. TO GO
TOTAL	PARCIAL				
0.000	0.000			<p>CONTROL "A" MARCA EN PISO</p> <p>N18°10.248' W97°41.928'</p>	9.630
1.330	1.330			!!!	8.300
1.850	0.520			PUENTE	7.780
2.290	0.440			POR CARRIL IZQUIERDO ENTRONQUE HUAXTEPEC !!	7.340
2.560	0.270			Km. 5 !!!	7.070

DISTANCIA A LA PRÓXIMA INSTRUCCIÓN	0.150
------------------------------------	-------

SS TC TC CH	7	JOLUXTLA	DISTANCIA	7
	8	LUNATITLÁN	9.630 Km.	
7	JOLUXTLA	8.020 Km.	PROMEDIO-AVERAGE	TIEMPO TIME
			58 Km/h	00:10

DISTANCIA		DIRECCIÓN DIRECTION	TIERRA	INFORMACIÓN INFORMATION	DIST. REG. TO GO
TOTAL	PARCIAL				
2.710	0.150			!!	6.920
3.590	0.880			KM. 6	6.040
4.840	1.250			!!	4.790
6.040	1.200			ENTRONQUE ACAQUIZAPAN !	3.590
7.340	1.300			DERECHA LARGA. !	2.290



DISTANCIA A LA PRÓXIMA INSTRUCCIÓN	0.200
------------------------------------	-------

SS TC TC CH	7	JOLUXTLA	DISTANCIA		7
	8	LUNATITLÁN	9.630 Km.		
7	JOLUXTLA		8.020 Km.	PROMEDIO-AVERAGE	TIEMPO TIME 00:10
				58 Km/h	

DISTANCIA		DIRECCIÓN	TIERRA	INFORMACIÓN INFORMATION	DIST. REG. TO GO
TOTAL	PARCIAL				
7.540	0.200			!! Y KM. 10	2.090
		11 0.480			
8.020	0.480			CONTROL "B" MARCA EN PISO Y ROCA L.D. N18°09.247' W97°44.447'	1.610
		12 0.000			
8.350	0.330			CONTROL "C" EN ENTRONQUE Y LETRERO MOVER A MEXICO	1.280
		13			
8.950	0.600			KM. 10	0.680
		14			
9.570	0.620			CONTROL "CH" MARCA EN PISO Y CASA L.I.	0.060
		15			

DISTANCIA A LA PRÓXIMA INSTRUCCIÓN	0.060
------------------------------------	-------

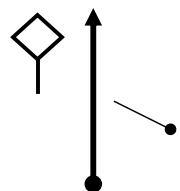
SS TC TC CH	7	JOLUXTLA	DISTANCIA		7
	8	LUNATITLÁN	9.630 Km.		
7	JOLUXTLA		8.020 Km.	PROMEDIO-AVERAGE	TIEMPO TIME 00:10
				58 Km/h	

DISTANCIA		DIRECCIÓN DIRECTION	TIERRA	INFORMACIÓN INFORMATION	DIST. REG. TO GO
TOTAL	PARCIAL				
9.630	0.060			 CONTROL "A" SEÑAL INVERTIDA LADO IZQUIERDO	0,000
		16			

DISTANCIA A LA PRÓXIMA INSTRUCCIÓN



1° RALLY RETO NOCTURNO

jmgf-18

www.cnrm.com.mx

45

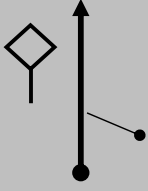
SS TC TC CH	8	LUNATITLÁN	DISTANCIA	8
	9	PLAN SAN MIGUEL	15.520 Km.	
8	LUNATITLÁN	9.100 Km.	PROMEDIO-AVERAGE	TIEMPO TIME
			62 Km/h	00:16

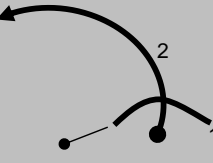
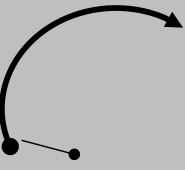
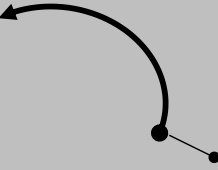
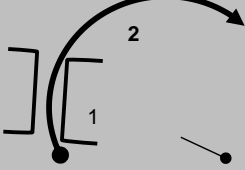
DISTANCIA		DIRECCIÓN DIRECCION	TIERRA	INFORMACIÓN INFORMATION	DIST. REG. TO GO
TOTAL	PARCIAL				
0.000	0.000			 CONTROL "A" SEÑAL INVERTIDA L.I. N18°09.715' W97°45.175'	15.520
		1	9.100		
1.220	1.220			1 LOMO 2 !!!	14.300
		2	7.880		
1.430	0.210			!!	14.090
		3	7.670		
2.120	0.690			!	13.400
		4	6.980		
2.310	0.190			1 PUENTE ANGOSTO 2 !!!	13.210
		5	6.790		

DISTANCIA A LA PRÓXIMA INSTRUCCIÓN	0.140
------------------------------------	-------

SS TC TC CH	8	LUNATITLÁN	DISTANCIA	8	
	9	PLAN SAN MIGUEL	15.520 Km.		
8	LUNATITLÁN		9.100 Km.	PROMEDIO-AVERAGE	
				62 Km/h	TIEMPO TIME 00:16

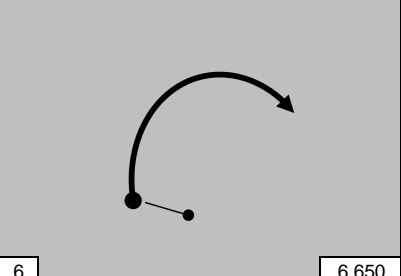
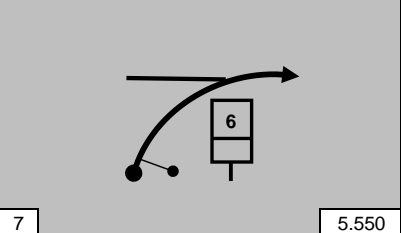
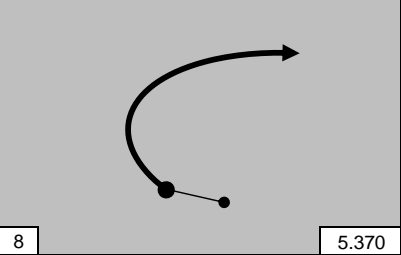
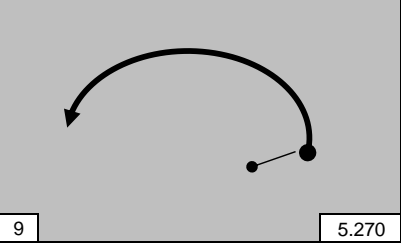
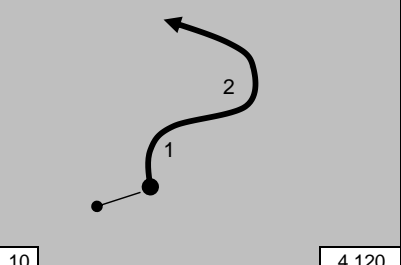
DISTANCIA		DIRECCIÓN DIRECTION	TIERRA	INFORMACIÓN INFORMATION	DIST. REG. TO GO
TOTAL	PARCIAL				
2.450	0.140			!!	13.070
3.550	1.100			KM. 6	11.970
3.730	0.180			!!	11.790
3.830	0.100			!	11.690
4.980	1.150			1 ! 2 !!	10.540

DISTANCIA A LA PRÓXIMA INSTRUCCIÓN 0.370

SS TC TC CH	8	LUNATITLÁN	DISTANCIA	8
	9	PLAN SAN MIGUEL	15.520 Km.	
8	LUNATITLÁN	9.100 Km.	PROMEDIO-AVERAGE	TIEMPO TIME
			62 Km/h	00:16

DISTANCIA		DIRECCIÓN DIRECCION	TIERRA	INFORMACIÓN INFORMATION	DIST. REG. TO GO
TOTAL	PARCIAL				
5.350	0.370			!! Y KM. 4	10.170
6.350	1.000			1 !! 2 !	9.170
7.890	1.540			!!	7.630
8.270	0.380			!!	7.250
9.100	0.830			CONTROL "B" MARCA EN PISO Y SEÑAL CURVA DER. N18°10.435' W97°42.139'	6.420



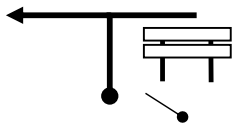
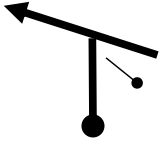
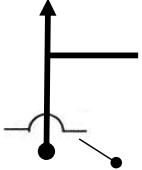
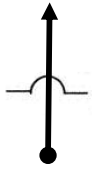
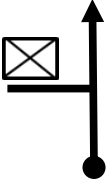

DISTANCIA A LA PRÓXIMA INSTRUCCIÓN	0.350
------------------------------------	-------

SS TC TC CH	8	LUNATITLÁN	DISTANCIA	8
	9	PLAN SAN MIGUEL	15.520 Km.	
8	LUNATITLÁN	9.100 Km.	PROMEDIO-AVERAGE	TIEMPO TIME
			62 Km/h	00:16

DISTANCIA		DIRECCIÓN DIRECCION	TIERRA	INFORMACIÓN INFORMATION	DIST. REG. TO GO
TOTAL	PARCIAL				
9.450	0.350			STOP CONTROL "C" LETRERO DOBLE A LA IZQUIERDA	6.070
		18			
11.620	2.170			ENTRONQUE CON CARR. FED. A LA IZQUIERDA "PRECAUCIÓN"	3.900
		19			
13.210	1.590			TOPE Y DE FRENTE	2.310
		18			
13.620	0.410			TOPES (4)	1.900
		19			
14.230	0.610			PEMEX LADO IZQUIERDO	1.290
		20			

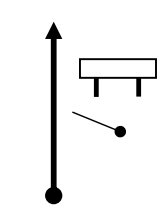

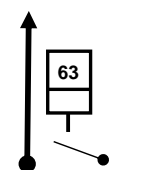
DISTANCIA A LA PRÓXIMA INSTRUCCIÓN	1.180
------------------------------------	-------

SS TC CH	8	LUNATITLÁN	DISTANCIA		8
	9	PLAN SAN MIGUEL	15.520 Km.		
8	LUNATITLÁN		9.100 Km.	PROMEDIO-AVERAGE	TIEMPO TIME
				62 Km/h	00:16

DISTANCIA		DIRECCIÓN DIRECTION	TIERRA	INFORMACIÓN INFORMATION	DIST. REG. TO GO
TOTAL	PARCIAL				
15.410	1.180			 CONTROL "CH" LETRERO "NO DEJE PIEDRAS..."	0.110
		21			
15.520	0.110			 CONTROL "A" KM. 63	0.000
		22			

DISTANCIA A LA PRÓXIMA INSTRUCCIÓN

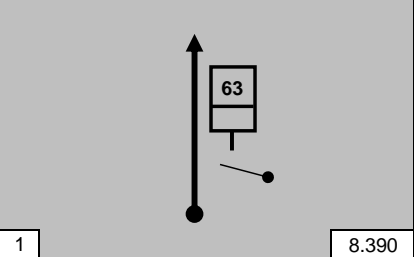
SS TC TC CH	9	PLAN SAN MIGUEL	DISTANCIA	9	
	10	COL. SAN MARTÍN	13.840 Km.		
9	PLAN SAN MIGUEL		8.390 Km.	PROMEDIO-AVERAGE	
				59.3 Km/h	TIEMPO TIME 00:14

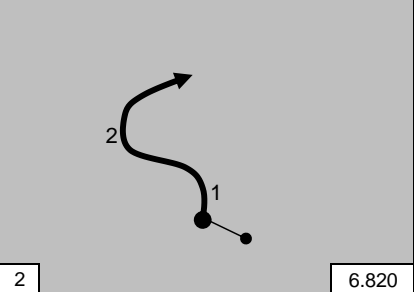
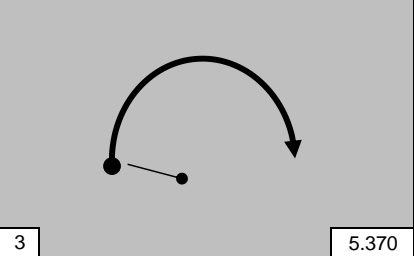
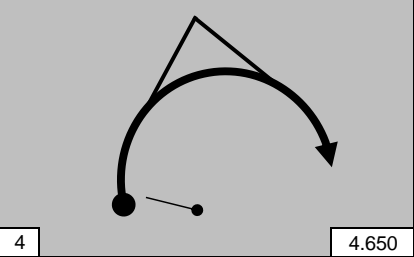
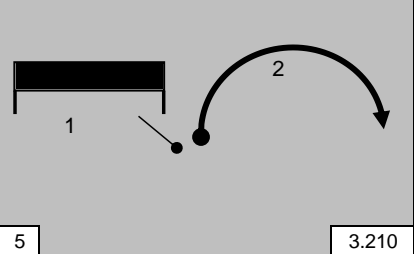
DISTANCIA		DIRECCIÓN DIRECCION	TIERRA	INFORMACIÓN INFORMATION	DIST. REG. TO GO
TOTAL	PARCIAL				
0.000	0.000			 CONTROL "A" KM. 63 N18°12.046' W97°40.394'	13.840
1.570	1.570			1 !! 2 !!	12.270
3.020	1.450			!!	10.820
3.740	0.720			!!	10.100
5.180	1.440			1 OAXACA 2 !!!	8.660



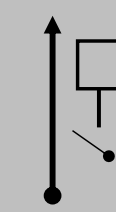
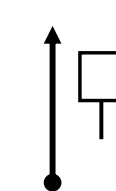
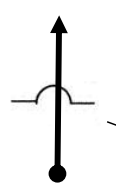
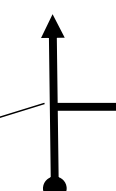

DISTANCIA A LA PRÓXIMA INSTRUCCIÓN	2.100
------------------------------------	-------

SS TC TC CH	9	PLAN SAN MIGUEL	DISTANCIA	9	
	10	COL. SAN MARTÍN	13.840 Km.		
9	PLAN SAN MIGUEL		8.390 Km.	PROMEDIO-AVERAGE	
				59.3 Km/h	TIEMPO TIME 00:14

DISTANCIA		DIRECCIÓN DIRECCION	TIERRA	INFORMACIÓN INFORMATION	DIST. REG. TO GO
TOTAL	PARCIAL				
7.280	2.100			1 !	6.560
8.390	1.110			CONTROL "B" SEÑAL 60 KM/H N18°12.822' W97°37.283'	5.450
8.940	0.550			STOP CONTROL "C" SEÑAL BUS AZUL	4.900
13.130	4.190			TOPE	0.710
13.270	0.140			DE FRENTE EN ENTRONQUE	0.570

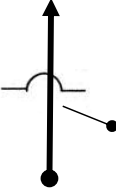
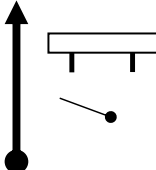

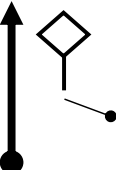
DISTANCIA A LA PRÓXIMA INSTRUCCIÓN	0.110
------------------------------------	-------

SS TC TC CH	9	PLAN SAN MIGUEL	DISTANCIA	9	
	10	COL. SAN MARTÍN	13.840 Km.		
9	PLAN SAN MIGUEL		8.390 Km.	PROMEDIO-AVERAGE	
				59.3 Km/h	TIEMPO TIME 00:14

DISTANCIA		DIRECCIÓN	TIERRA	INFORMACIÓN INFORMATION	DIST. REG. TO GO
TOTAL	PARCIAL				
13.880	0.110			TOPES (2)	0.460
		11			
13.780	0.400			 CONTROL "CH" LETRERO "CONCEDA..."	0.060
		12			
13.840	0.060			 CONTROL "A" SEÑAL "PENDIENTE" LADO DERECHO	0.000
		13			
		14			
		15			

DISTANCIA A LA PRÓXIMA INSTRUCCIÓN	0.060
------------------------------------	-------

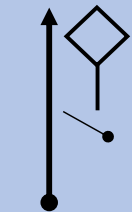
SS TC TC CH	10	COL. SAN MARTÍN	DISTANCIA	10	
	10A	META EN WALMART TEHUACÁN	44.530 Km.		
10	COL. SAN MARTÍN		8.700 Km.	PROMEDIO-AVERAGE	
				56.8 Km/h	TIEMPO TIME 00:47

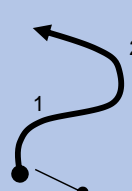
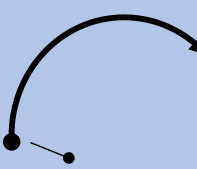
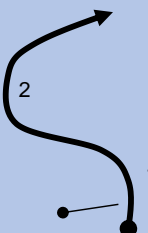
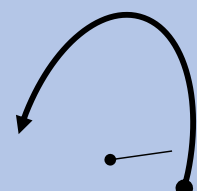
DISTANCIA		DIRECCIÓN DIRECTION	TIERRA	INFORMACIÓN INFORMATION	DIST. REG. TO GO
TOTAL	PARCIAL				
0.000	0.000			 CONTROL "A" SEÑAL "PENDIENTE" N18°13.969' W97°34.718'	44.530
0.660	0.660			1 !! 2 !!	43.870
2.020	1.360			!!	42.510
3.640	1.620			1 ! 2 !!	40.890
4.420	0.780			!!!	40.110

DISTANCIA A LA PRÓXIMA INSTRUCCIÓN 0.720

SS TC TC CH	10	COL. SAN MARTÍN	DISTANCIA	10	
	10A	META EN WALMART TEHUACÁN	44.530 Km.		
10	COL. SAN MARTÍN		8.700 Km.	PROMEDIO-AVERAGE	
				56.8 Km/h	TIEMPO TIME 00:47

DISTANCIA		DIRECCIÓN DIRECTION	TIERRA	INFORMACIÓN INFORMATION	DIST. REG. TO GO
TOTAL	PARCIAL				
5.140	0.720			1 !! 2 !!	39.390
6.480	1.340			1 ! 2 !!	38.050
8.700	2.220			CONTROL "B" LETRERO OBEDEZCA... N18°16.209' W97°32.539'	35.830
9.520	0.820			CONTROL "C" EN TOPE	35.010
9.740	0.220			TOPES (2)	34.790

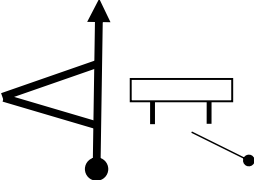
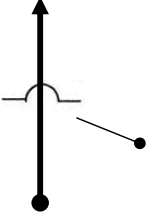
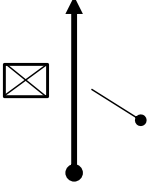
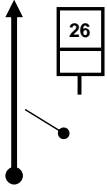
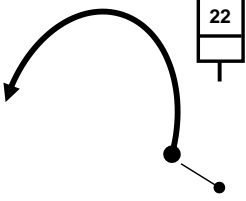

DISTANCIA A LA PRÓXIMA INSTRUCCIÓN 4.070

SS TC TC CH	10	COL. SAN MARTÍN	DISTANCIA	10	
	10A	META EN WALMART TEHUACÁN	44.530 Km.		
10	COL. SAN MARTÍN		8.700 Km.	PROMEDIO-AVERAGE	
				56.8 Km/h	TIEMPO TIME 00:47

DISTANCIA		DIRECCIÓN DIRECTION	TIERRA	INFORMACIÓN INFORMATION	DIST. REG. TO GO
TOTAL	PARCIAL				
13.810	4.070			DE FRENTE STA. ANA TELOXTOC	30.720
		11			
19.320	5.510			TOPES (5) ZAPOTITLÁN	25.210
		12			
20.650	1.330			PEMEX LADO IZQUIERDO	23.880
		13			
21.130	0.480			KM. 26	23.400
		14			
24.900	3.770			!!! KM. 22	19.630
		15			

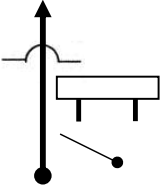
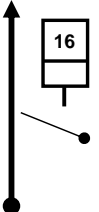
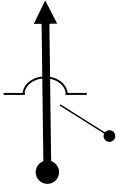
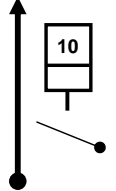

DISTANCIA A LA PRÓXIMA INSTRUCCIÓN 1.030

SS TC TC CH	10	COL. SAN MARTÍN	DISTANCIA	10	
	10A	META EN WALMART TEHUACÁN	44.530 Km.		
10	COL. SAN MARTÍN		8.700 Km.	PROMEDIO-AVERAGE	
				56.8 Km/h	TIEMPO TIME 00:47

DISTANCIA		DIRECCIÓN DIRECTION	TIERRA	INFORMACIÓN INFORMATION	DIST. REG. TO GO
TOTAL	PARCIAL				
25.930	4.070			LETRERO "ZONA URBANA" TOPES (2)	18.600
		16			
31.160	5.230			KM. 16	13.370
		17			
31.490	0.330			TOPES (4)	13.040
		18			
37.250	5.760			KM. 10	7.280
		19			
38.500	1.250			POR LA DERECHA	6.030
		20			

DISTANCIA A LA PRÓXIMA INSTRUCCIÓN 0.490

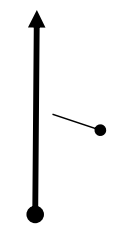
SS TC TC CH	10	COL. SAN MARTÍN	DISTANCIA	10	
	10A	META EN WALMART TEHUACÁN	44.530 Km.		
10	COL. SAN MARTÍN		8.700 Km.	PROMEDIO-AVERAGE	
				56.8 Km/h	TIEMPO TIME 00:47

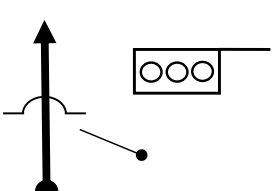
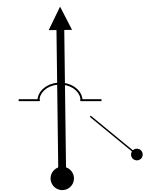
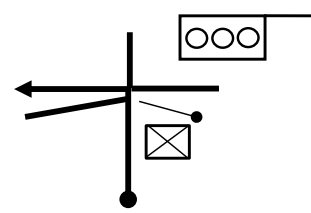
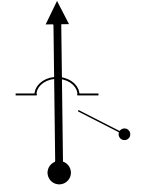
DISTANCIA		DIRECCIÓN DIRECTION	TIERRA	INFORMACIÓN INFORMATION	DIST. REG. TO GO
TOTAL	PARCIAL				
38.990	0.490			 TEHUACAN	5.540
		21			
39.360	0.370			TOPE Y SEMÁFORO	5.170
		22			
39.600	0.240			TOPES (4)	4.930
		23			
40.770	1.170			A LA IZQUIERDA POR LIBRAMIENTO (I. TECNOLÓGICO DE TEH.)	3.760
		24			
41.090	0.320			TOPE	3.440
		25			

DISTANCIA A LA PRÓXIMA INSTRUCCIÓN 0.530

SS TC TC CH	10	COL. SAN MARTÍN	DISTANCIA	10	
	10A	META EN WALMART TEHUACÁN	44.530 Km.		
10	COL. SAN MARTÍN		8.700 Km.	PROMEDIO-AVERAGE	
				56.8 Km/h	TIEMPO TIME 00:47

DISTANCIA		DIRECCIÓN DIRECTION	TIERRA	INFORMACIÓN INFORMATION	DIST. REG. TO GO
TOTAL	PARCIAL				
41.620	0.530			TOPE Y SEMÁFORO	2.910
		26			
42.280	0.660			TOPES (2)	2.250
		27			
42.680	0.400			TOPE	1.850
		28			
43.140	0.460			SEMÁFORO DE FRENTE (PEMEX)	1.390
		29			
43.320	0.180			TOPE	1.210
		30			

DISTANCIA A LA PRÓXIMA INSTRUCCIÓN 0.220

SS TC TC CH	10	COL. SAN MARTÍN	DISTANCIA	10	
	10A	META EN WALMART TEHUACÁN	44.530 Km.		
10	COL. SAN MARTÍN		8.700 Km.	PROMEDIO-AVERAGE	
				56.8 Km/h	TIEMPO TIME 00:47

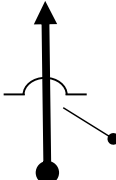
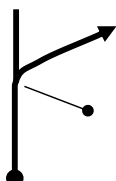
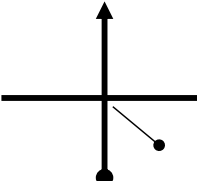
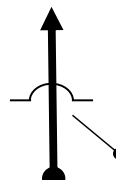
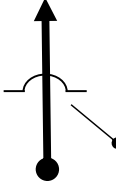
DISTANCIA		DIRECCIÓN DIRECTION	TIERRA	INFORMACIÓN INFORMATION	DIST. REG. TO GO
TOTAL	PARCIAL				
43.540	0.220			TOPE	0.990
		31			
43.690	0.150			A LA DERECHA POR CALLE BENITO JUÁREZ.	0.840
		32			
43.820	0.130			DE FRENTE PRECAUCIÓN (HACER ALTO)	0.710
		33			
43.980	0.160			TOPES (2)	0.550
		34			
44.220	0.240			TOPE	0.310
		25			

DISTANCIA A LA PRÓXIMA INSTRUCCIÓN 0.250

SS TC TC CH	10	COL. SAN MARTÍN	DISTANCIA	10	
	10A	META EN WALMART TEHUACÁN	44.530 Km.		
10	COL. SAN MARTÍN		8.700 Km.	PROMEDIO-AVERAGE	
				56.8 Km/h	TIEMPO TIME 00:47

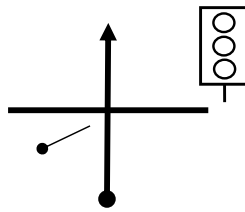
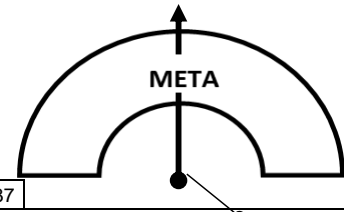
DISTANCIA		DIRECCIÓN	TIERRA	INFORMACIÓN	DIST. REG.
TOTAL	PARCIAL	DIRECTION		INFORMATION	TO GO
44.470	0.250			SEMÁFORO DE FRENTE	0.060
		36			
44.530	0.060			META FIN DEL RALLY WALMART TEHUACÁN "FELICIDADES"	0.000
		37			